

AIRSYS



OPTIMA

Precision Air Conditioners for
Critical Applications

Cooling capacity: 9.6kW~134.5kW



The OPTIMA product family from AIRSYS is designed specifically for medium to large data center installations. OPTIMA units combine precise temperature and humidity control with outstanding reliability and energy efficiency, throughout 24*7 operation.

The OPTIMA range of precision air conditioners offers various heat-rejection options to meet the needs of any installation, and the OPTIMA-INV series includes an energy efficient inverter compressor. Other energy-saving technologies incorporated into the OPTIMA series include options for EC fans, free cooling and dual cooling sources.

Unit Identification

01 Product Type

OPTIMA: OPTIMA precision air conditioner, abbr. as OPT
OPTIMA-INV: OPTIMA-INV precision air conditioner with inverter compressor, abbr. as OPTV

07 Heat-Rejection

DXA—Direct expansion with air cooled condenser
DXW—Direct expansion with water cooled condenser
CW—Chilled water cooling single coil(not available for OPTIMA-INV)
CWD—Chilled water cooling double coil(not available for OPTIMA-INV)

09 Compressor Type and Number

E1- OPTIMA, 1 compressor
E2- OPTIMA, 2 compressors
V1- OPTIMA-INV, 1 compressor
V2- OPTIMA-INV, 2 compressors

03 Free Cooling/Dual Cooling Sources Unit

FC—Indirect free cooling(not available for CW/CWD unit)
DC—Dual cooling sources (not available for CW/CWD unit)
DFC—Direct free cooling
Default— Without free cooling or dual cooling sources

05 Air Supply Scheme

OVER— Up flow, abbr. as "O"
UNDER— Down flow, abbr. as "U"

11 Refrigerant

OPTIMA: R407=R407C
OPTIMA-INV: R410=R410A

13 Power source

Voltage/Phase/Frequency
Default=380/3/50

15 Separator Character "."

01	02	03	04	05	06	07	08	09	10	11	12	13	14	15	16
OPTIMA OPTIMA-INV	-	FC DC DFC	.	O U	.	DXA DXW CW CWD	16 20 ...	E1 E2 V1 V2	A1 ... A5	R407 R410	.	380/3/50	FEA FEC	.	XXX

02 Separator Character "."

04 Separator Character "."

06 Separator Character "."

10 Cabinet Size Code

OPTIMA adopt "A" cabinet with 5 sizes A1-A5

12 Separator Character "."

14 Fan Type

FEA-EC supply fan, AMAE series outdoor unit
FEC-EC supply fan, CME series outdoor unit

08 Nominal Cooling Capacity: kW

16 Code for Custom Design
3 alphabetic and numerical code

For example: OPTV-DFC.U.DXA40V1A3R410.380/3/50.FEA

Stands for OPTIMA-INV Precision Air Conditioner with direct free cooling; air supply scheme is down flow; heat-rejection via direct expansion with air cooled condenser; cooling capacity is 40kW; equipped with 1 inverter compressor; cabinet size is A3; R410A refrigerant; the input power supply is 380V/3Ph/50Hz; supply fan is EC centrifugal fan; outdoor unit is AMAE series.

Standard configurations for the OPTIMA family of products:

Product Type	FC/DC Unit	Cooling Type	Air Supply	Cabinet	Cooling Capacity	
OPTIMA	None	DXA	O/U	A1~A5	18.9~103.4kW	
		DXW			27.9~106.7kW	
		CW			24.8~134.5kW	
		CWD			24.8~134.5kW	
		DXA			16.5~104.6kW	
		DXW			27.9~106.7kW	
	FC	DXA			16.5~104.6kW	
		DXW			27.9~106.7kW	
		DC			DXA	9.7~103.4kW
					DXW	15.0~106.7kW
					CW	11.4~134.5kW
					CWD	11.4~134.5kW
DFC	DXA		18.2~102.3kW			
	DXW		26.7~105.6kW			
	None	DXA	18.2~116.2kW			
		DXW	26.7~116.2kW			
		FC	DXA	18.2~116.2kW		
			DXW	26.7~116.2kW		
DC			DXA	9.6~102.3kW		
			DXW	12.6~105.6kW		
	DFC		DXA			
			DXW			

Heat-Rejection Options

Air cooled direct expansion system(DXA)

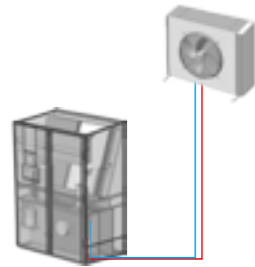

Air cooled direct expansion system (DXA) includes throttle, evaporator coil, scroll compressor and refrigeration piping configuration.

Heat from the indoor air is transferred to the refrigerant at the evaporator coil and rejected to the outside air via the air-cooled condenser.

Indoor unit: OPTIMA(-INV).DXA

Outdoor unit: CME series air-cooled condenser, AMAE series air-cooled condenser

Water cooled direct expansion system(DXW)

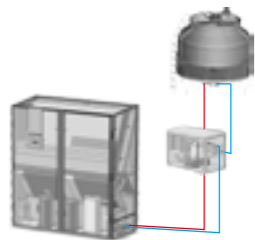

The water cooled direct expansion system (DXW) operates similarly to the air cooled system, however the refrigerant transfers the rejected heat to water via a plate heat exchanger, which is then discharged to the outside air via a dry cooler or cooling tower.

Refrigerant is pre-charged, the cooling pipe has been sealed and the unit is thoroughly tested in the factory. No refrigerant pipe installation is required on site, making unit installation significantly easier.

Indoor unit: OPTIMA(-INV).DXW

Outdoor unit: CMEH series dry cooler(AIRSYS)/cooling tower(user supplied)

Single coil chilled water system(CW)

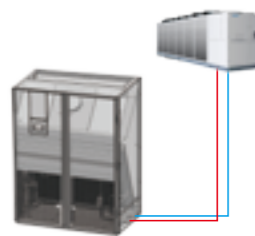

The single coil chilled water system (CW) transfers heat from the indoor air directly to a chilled water circuit. The user can connect to a new or existing chilled water source.

Indoor unit: OPTIMA.CW

Outdoor unit: user supplied chilled water source

Double coil chilled water system(CWD)

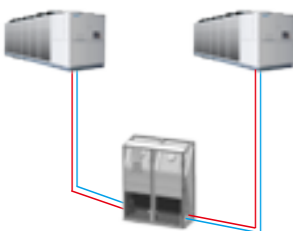

Double coil chilled water systems (CWD) each contain two independent chilled water circuits and connect to independent cooling sources. The two circuits are utilized for redundancy.

Indoor unit: OPTIMA.CWD

Outdoor unit: user supplied chilled water source

Air cooled direct expansion with indirect free cooling(FC.DXA)

The FC.DXA unit is a dual-circuit system combining DXA heat-rejection with indirect free cooling (FC). The circuits are independent.

When there is a call for cooling, and the difference between indoor and ambient temperatures is acceptable, the FC unit will run to provide indirect free cooling through rejecting heat via a dry cooler. Only when free cooling capacity is insufficient to meet the cooling demand will the DXA unit start up mechanical cooling. Reduced run hours of the DXA system through the use of the FC unit saves energy.

Indoor unit: OPTIMA(-INV)-FC.DXA

Outdoor unit: CME, AMAE air cooled condenser, CMEH dry cooler, PUG pump kit

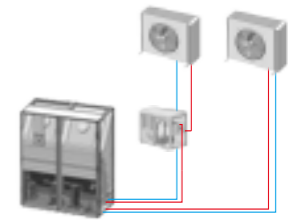

Water cooled direct expansion with indirect free cooling(FC.DXW)

The FC.DXW unit is a single-circuit system combining DXW mechanical cooling with indirect free cooling (FC); the two cooling modes share the same water system.

When there is a call for cooling, and the difference between indoor and ambient temperatures is acceptable, the FC unit will run to provide indirect free cooling through rejecting heat via a dry cooler. Only when free cooling capacity is insufficient to meet the cooling demand will the DXW unit start up mechanical cooling. Reduced run hours of the DXW system through the use of the FC unit saves energy.

Indoor unit: OPTIMA(-INV)-FC.DXW

Outdoor unit: CMEH dry cooler/cooling tower, PUG pump kit

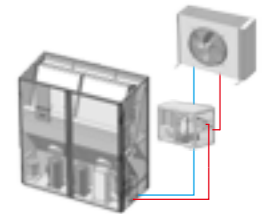

Air cooled direct expansion with double cooling source(DC.DXA)

The DC.DXA unit is a dual-circuit system offering both DXA (air cooled) mechanical cooling and chilled water cooling (CW). It contains two independent cooling circuits with different heat-rejection methods for redundancy.

Indoor unit: OPTIMA(-INV)-DC.DXA

Outdoor unit: CME, AMAE air cooled condenser, PUG pump kit, CMEH dry cooler, user supplied chilled water source

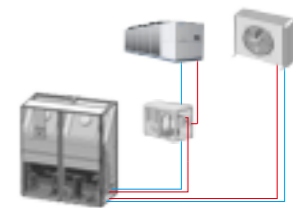

Water cooled direct expansion with double cooling source(DC.DXW)

The DC.DXW unit is a dual-circuit system offering DXW (water cooled) mechanical cooling and chilled water cooling (CW). It contains two independent cooling circuits with different heat-rejection methods for redundancy.

Indoor unit: OPTIMA(-INV)-DC.DXW

Outdoor unit: PUG pump kit, CMEH dry cooler, user supplied chilled water source

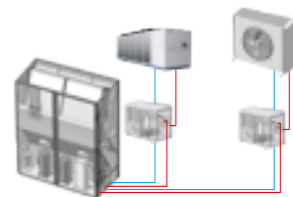

Operating Range & Control Accuracy

DXA

Operating Range

Outdoor Temperature:

-40°C ~ +55°C (special options are available for extreme temperature conditions)

Piping Length:

Total length of 30 meters of gas and liquid refrigeration piping loop (consult AIRSYS sales representative for specific installation arrangement)

Piping Vertical Distance:

Condenser above indoor unit: max. 20m

Condenser below indoor unit: max. 5m

consult AIRSYS sales representative for specific installation arrangement)

Control Accuracy

Temperature Range and Accuracy:

Range: 15~35°C, Accuracy: ±1°C;

Humidity Range and Accuracy:

Range: 35~80%, Accuracy: ±5%

DXW/CW/CWD

Operating Range

Water pressure specification:

Higher than the system total pressure drop, but lower than 1250kPa

Control Accuracy

Temperature Range and Accuracy:

Range: 15~35°C, Accuracy: ±1°C

Humidity Range and Accuracy:

Range: 35~80%, Accuracy: ±5%

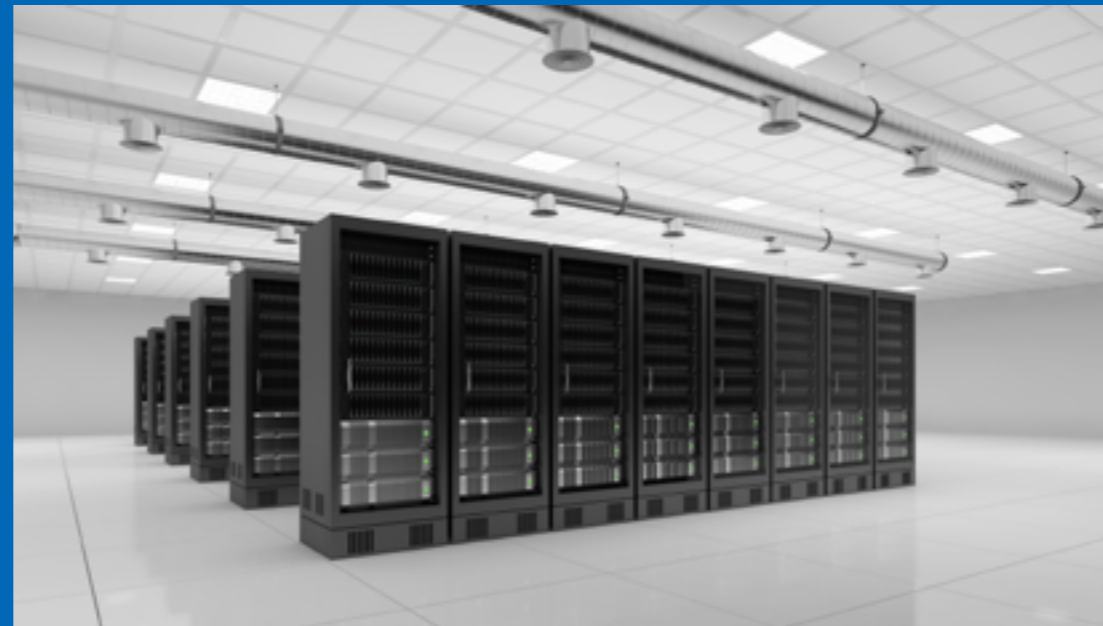

Application

Computer Rooms and Data Centers

Telecom Equipment Rooms and Shelters

Other Electronic Equipment Rooms

Healthcare Equipment Rooms

Laboratories with precise environmental requirements

Manufacturing facilities requiring precise environments

Storage facilities requiring precise environments such as museums and wine cellars



High Lights

Precise Control

The control accuracy for temperature is $\pm 1^{\circ}\text{C}$ and for Relative humidity is $\pm 5\%$.

Various Heat-Rejection Arrangements

Heat-Rejection arrangements include DX air cooled, DX water cooled, chilled water with single coil or double coil, DX air cooled/water cooled with direct free cooling (DFC), DX air cooled/water cooled with indirect free cooling (FC) and double cooling sources (DC). Options are available to suit all installation requirements.

Various Supply Air Arrangements

Supply air arrangements include top discharge (up flow) and bottom discharge (down flow). Return air arrangements, include top return, bottom return, front return and rear return to meet all varied requirements of ICT sites.

Corrosion-proof

The unit framework is provided with corrosion protection treatment. The treatment is sufficient to provide protection for a 15 year life cycle for inland installation.

If necessary, the treatment for sea air environment can be supplied as an option.

Easy Maintenance

The technical compartment housing the compressor, humidifier, control and safety devices is separates from the air flow, enabling ordinary service and preventive maintenance to occur during operation.

EC Fan

Highly efficient EC fans are supplied with OPTIMA products.

Scroll Compressor

OPTIMA (DXA & DXW) units are equipped with scroll compressors, which produce less vibration, lower noise and greater efficiencies. OPTIMA-INV units are equipped with s scroll inverter compressor which can vary speed continuously according to the cooling demand.

Isolated Control Panel

All the electrical and control components are installed in an isolated control panel with orderly wiring and clear labeling, meeting the IEC standards.

Continuous Control System for Condensing Pressure

DXA

The unit is installed with a pressure sensor which is used for the fan speed control of the outdoor unit, therefore maintaining refrigeration system pressure within a suitable range and ensuring the stable operation of the system.

When compared to On/Off condensing control, the OPTIMA system increases the energy saving significantly and extends the working life of the compressor. It also enables the unit to startup and work at low ambient temperatures (to -40°C or lower)

DXW

The unit is installed with a pressure sensor which is used for the water flow valve control at the outdoor unit, therefore maintaining refrigeration system pressure within suitable range and ensuring the stable operation of the system.

Forced Dehumidification System

The dehumidification process occurs through decreasing the evaporator coil surface temperature or reducing the air flow across the coil. These features enable faster dehumidification, increased energy savings and more precise humidity control.

Electrode Humidifier

An electrode humidifier, controlled by a microprocessor, monitors and adjusts the humidifying capacity precisely, while the water quality monitoring and wash extends the maintenance interval, prolonging the working life of the unit.

Electric Heater

The construction of the electric heater element (stainless steel pipe with wrapped fins) allows for a reduced operating temperature, therefore eliminating ionization, and avoiding unpleasant odors.

Air Filter

A washable, easy maintainable and durable G4 class air filter is a standard configuration for the OPTIMA range. With optional air pressure switch, a clogged filter alarm can be triggered when the filter is dirty.

Self-diagnosis

All the microprocessor-connected components are continuously monitored and controlled and, in case of malfunction, the unit is shut down and the fault is shown on the display.





Supply Air Temperature and Pressure Control (option)

Supply air temperature control, as the name suggests, means driving the operation of the compressor based on the air temperature at the supply air discharge location; when cool air is being supplied at the setpoint temperature, the compressor is stopped until supply air temperature begins to increase. This control method provides accurate adjustment of the cooling capacity according to actual demand and can save a considerable amount of energy.

Supply air temperature control is typically applied to cold aisle cooling systems. As the cold aisle temperature profile is uniform (i.e. there is no short-circuiting of air), accurate reading of the supply air temperature is simple to obtain from the unit supply air discharge location.

Because the supply air and cold aisle air temperatures are equal, the cold air is supplied directly to the equipment requiring cooling and no energy is wasted cooling the rest of the room. Compared to return air temperature control systems, supply air control systems can operate at a higher supply air temperature under the same cooling demand conditions. As well as this, evaporating temperatures will typically be higher and therefore more energy efficient.

For down flow units utilizing supply air temperature control, the differential air pressure can be monitored to ensure the cool air has been evenly distributed to all the servers.

Energy Saving Technologies

Optional Energy Saving Running Modes

The OPTIMA family of products offers two running modes which may be chosen from the controller display:

Standard running mode:

In this mode, the temperature and humidity are controlled within narrower ranges;

Energy saving mode:

In this mode, good energy savings can be achieved through allowing the temperature and humidity to be controlled within wider ranges.

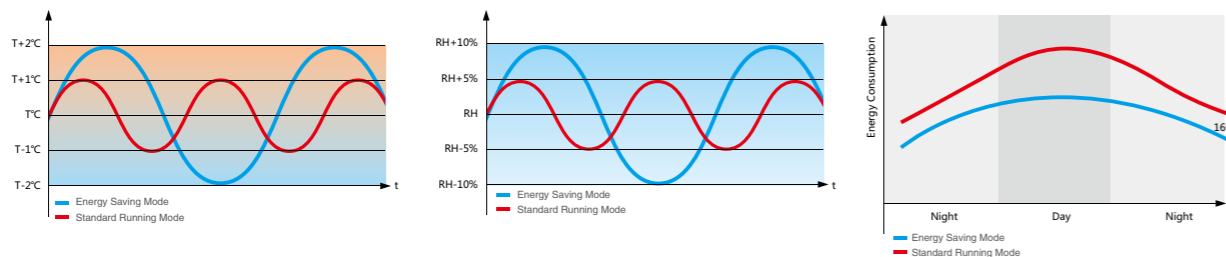
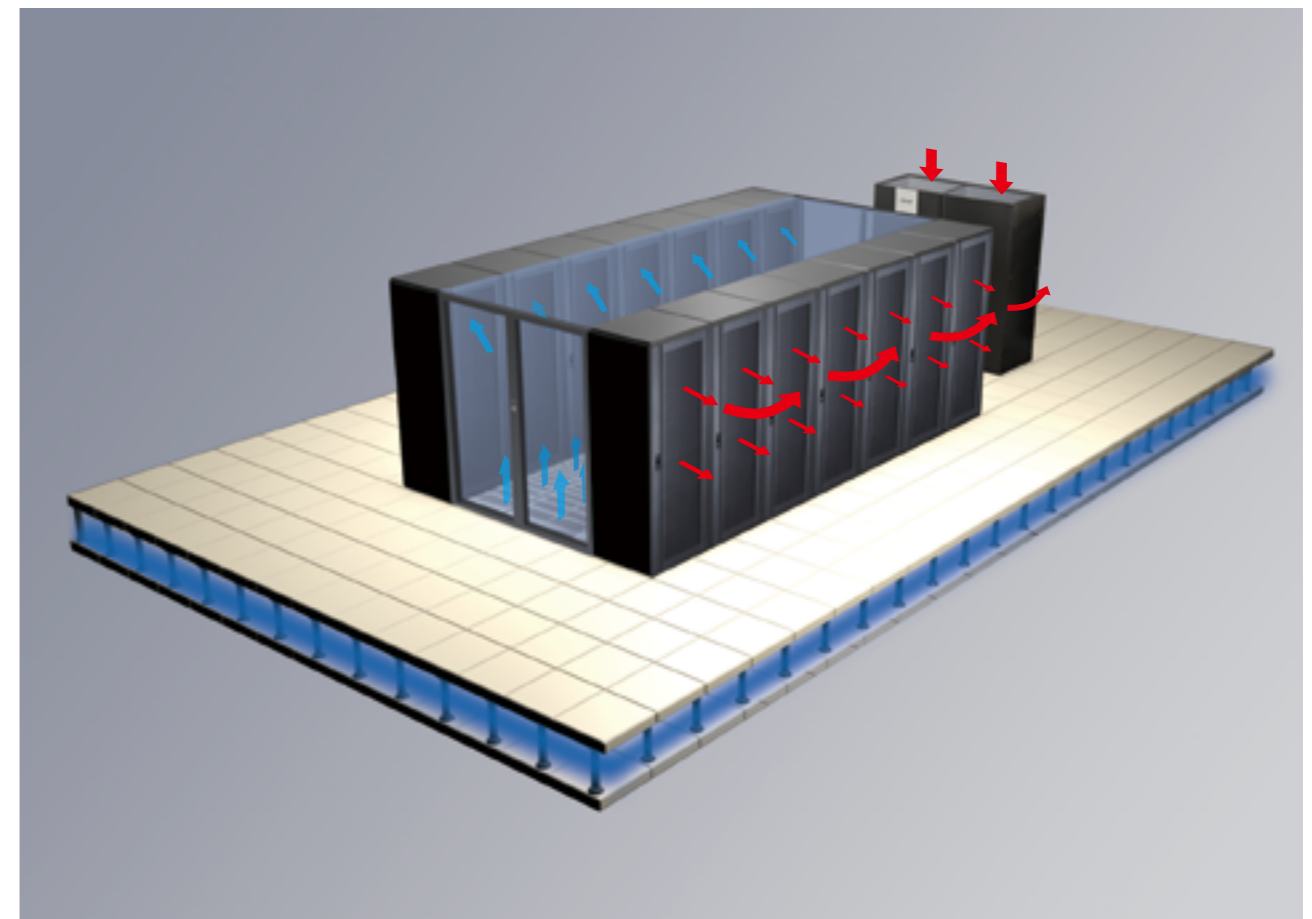

EC Fan

An EC fan refers to a centrifugal fan that utilizes an Electronically Commutated motor (or brushless DC motor). EC fans have numerous benefits including:

Energy Efficiency

EC fans have brushless DC motors and integrated control modules. Motor efficiencies of 85-90% are achievable; 30% to 50% higher than traditional AC fans. The difference in energy efficiency between variable speed EC fan control and traditional on/off fixed speed AC fans can be seen in the graph; the bars show the power consumption of fans which are switched in gradually as required while the blue curve shows the power consumption with infinitely variable speed control.

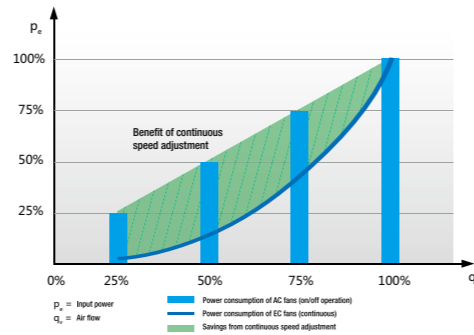

Lower Noise

In a given installation, switching off half the fans (and halving the air flow) will typically only reduce the generated noise by approximately 3 dB. Compare this to EC fans, where reducing fan speed to provide half the air flow typically yields a reduction of approximately 15 dB. This is possible as EC fans are able to operate across an infinitely controllable speed range, which in turn effectively avoids electromagnetic and rectifier noise (generated by other traditional motor and speed control devices), thus reducing the overall noise level.

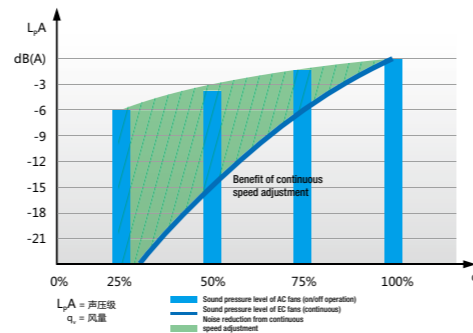

In the graph, the bars indicate the sound pressure level of fans which are switched in gradually as required and the blue curve shows the sound pressure level with infinitely variable speed control.

As can be seen from the picture EC fan sound pressure level is 12dB lower compared to the traditional AC fan.

Compact, Integrated Electronic Control System

All EC fans have dedicated speed control modules and filters built into the motor assembly, making for a compact and self-contained solution. All that is required is to connect the main power supply and the sensor signals to the controller for complete speed control of between 10% and 100%. EC fans provide a simple, convenient solution and can also support group control and remote monitoring.



Wide Working Voltage

Wide AC input voltage range: 1~200-277VAC or 3~380-480VAC 50&60Hz
Wide DC input voltage range: 16-28VDC or 36-57VDC

Inverter Technology

OPTIMA-INV inverter series precision air conditioners adopt energy-efficient DC inverter scroll compressors that can achieve stepless speed and on-demand cooling capacity adjustment to achieve the greatest efficiencies. Inverter technology is available with direct expansion air-cooled (DXA) and direct expansion water cooled (DXW) type units.



The inverter system manages the compressor speed with infinitely variable control according to the actual cooling demand;. When the difference between room and setpoint temperatures is high, the compressor operates at a high speed (and greater cooling capacity). As the temperature difference reduces, the compressor speed gradually reduces to more accurately maintain room temperature (a subsequently conserving energy).

High Efficiencies, Lower Noise

Compared to the on/off operation of fixed-speed compressors, inverter compressors have stepless speed changes which, through intelligent control, consistently aim to run at the most efficient operating point . This variable frequency operation can save nearly 30% on operating costs.

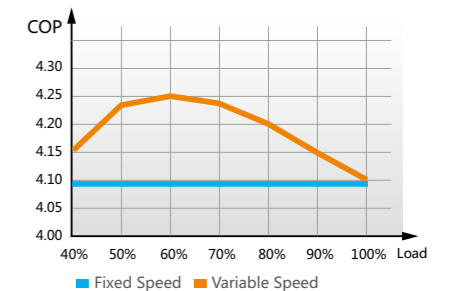

Results from an AIRSYS performance test of fixed-frequency vs. inverter compressors can be seen in the graph; the stark difference between compressor COPs is easily seen.

Additionally, an inverter compressor starting current is only about 10% of that of a fixed-frequency compressor, they typically have a higher reliability and the noise generated at part load is approximately 5-10 dB lower.

More Precise Temperature Control

Compared to a fixed-frequency compressor, an inverter compressor can achieve more precise temperature control through maintaining the room temperature closer to the setpoint temperature. The control accuracy can be as close as $\pm 0.5\text{ }^{\circ}\text{C}$, even when the load is constantly changing. The comparison between fixed-frequency and inverter compressor temperature control accuracy is shown on the right picture.

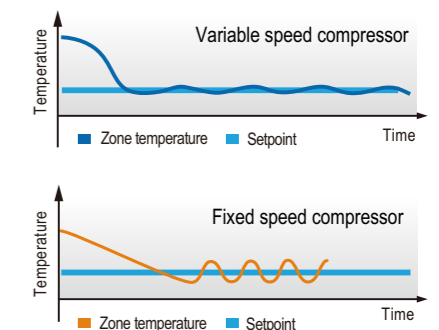

OPTIMA-INV Inverter Series precision air conditioners utilize electronic expansion valves to regulate the refrigerant flow entering the evaporator and match it to the running speed of the compressor. Compared to thermal expansion valves, electronic expansion valves control much more accurately and efficiently. They are also able to control system evaporation temperature and superheat more effectively and lead to an overall higher system efficiency.



For OPTIMA-INV parameters, please refer to P29-P30.

Data center power consumption is generally divided between four major sources; IT equipment, cooling systems, backup power and lighting systems. The specific proportions are different in each data centers, however a typical split is presented here.

As the pie chart show, the energy consumption of the cooling system is second only to the actual IT equipment; i.e. the air conditioning systems account for a large portion of the total energy consumption of the data center. Therefore, by taking advantage of free cooling solutions (and hence reducing the run hours of the compressors) large energy savings are potentially achievable. AIRSYS has developed both direct and indirect free cooling systems, as well as dual heat-rejection mode units which can significantly reduce the overall energy consumption of a data center. Options are available or configurable to suit any and all installation requirements.

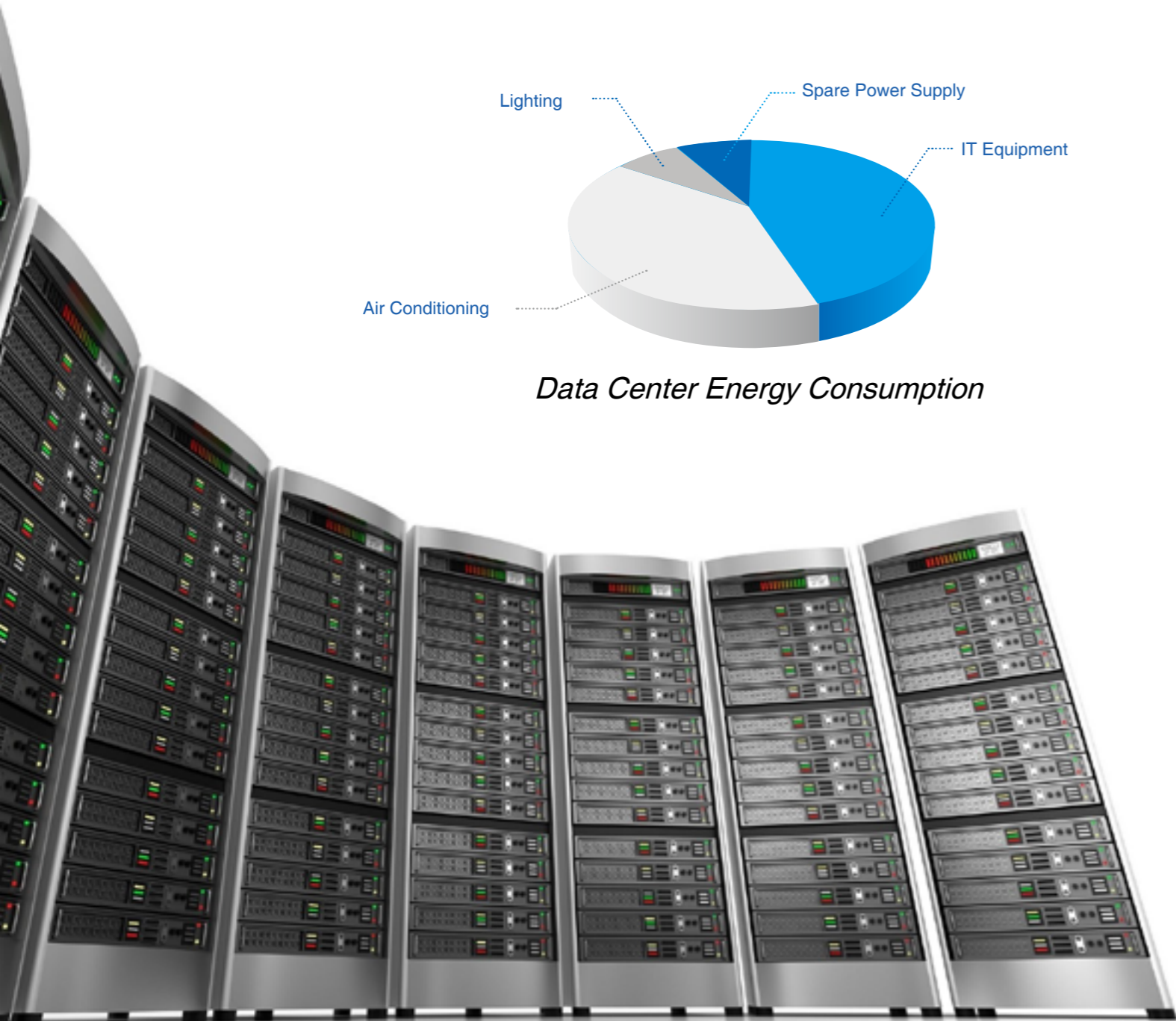
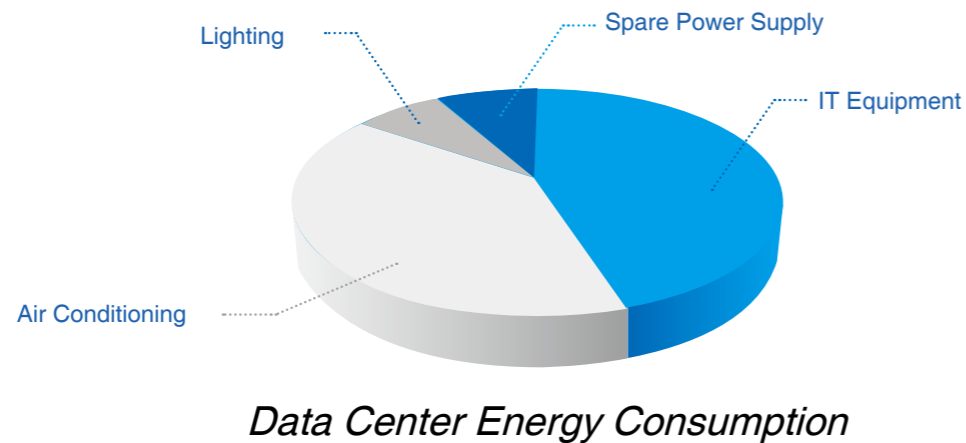

Indirect Free Cooling

Indirect free cooling refers to heat-rejection through circulating water between an indoor cooling coil and an outdoor dry cooler or cooling tower; the water absorbs the heat at the indoor coil and then discharges it to the atmosphere via the dry cooler or cooling tower.

Air cooled direct expansion unit with indirect free cooling(FC)

By adding a water coil to the direct-expansion evaporator coil and completing an indirect free cooling (FC) circuit with a dry cooler or cooling tower, significant energy savings can be made through a reduction in the DX compressor run hours. When there is a call for cooling, and the difference between indoor and ambient temperatures is acceptable, the FC system will run to provide indirect free cooling. If the FC system can not satisfy the total cooling demand, the DX cooling system will commence operation, however, as the outdoor ambient temperature decreases, the proportion of FC capacity will increase. When free cooling capacity reaches 100%, and cooling demand is being met, complete FC mode is achieved and there is no compressor power consumption from the DX system.

Both OPTIMA and OPTIMA-INV units can accommodate the indirect free cooling option. The corresponding series are OPTIMA-FC.DXA and OPTIMA-INV-FC.DXA. For the specific technical parameters, please refer to P23 and P29. The schematic diagram showing the principle of operation for an air cooled direct expansion unit with indirect free cooling (FC) is as follows:

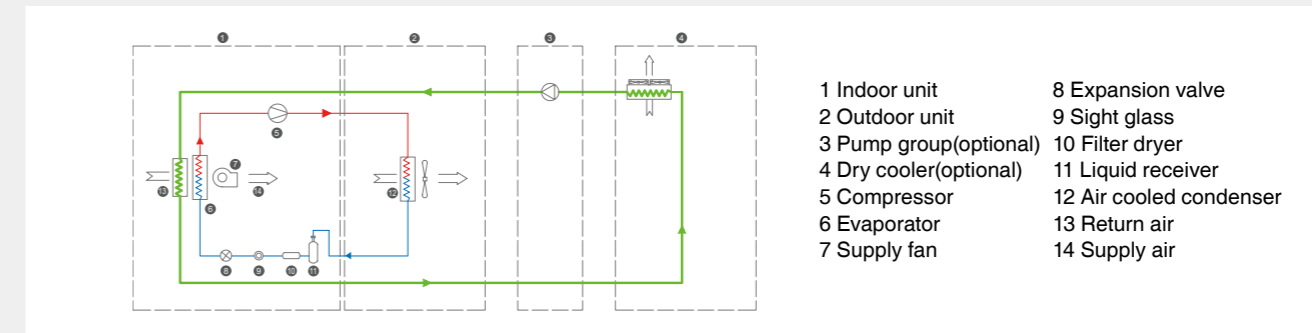

Water cooled direct expansion unit with indirect free cooling(FC)

A FC water coil can be added to the direct-expansion evaporator coil to introduce FC ability. The unit then automatically determines whether the water should flow through the plate heat exchanger (for DX cooling) or the water coil (for FC operation) via a three-way valve. A single outdoor dry cooler provides heat-rejection water for both the direct-expansion plate heat exchanger and the FC coil, reducing required plant space and allowing energy savings through reduced compressor power consumption.

Both OPTIMA and OPTIMA-INV units can accommodate the indirect free cooling option. The corresponding series are OPTIMA-FC.DXW and OPTIMA-INV-FC.DXW. For the specific technical parameters, please refer to P25 and P30. The schematic diagram showing the principle of operation for a water cooled direct expansion unit with indirect free cooling (FC) is as follows:

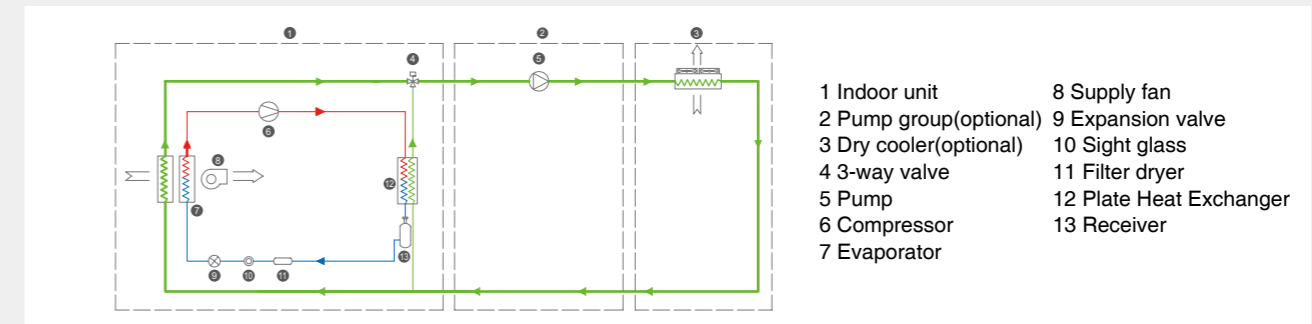

Direct Free Cooling(DFC)

For installations where outdoor temperatures are commonly lower than indoor temperature, fresh air can be introduced directly into the room to cool the equipment; this is known as direct free cooling (DFC). A well designed and integrated DFC system can greatly reduce the dependency on other cooling systems and save energy through minimizing their run hours. DFC systems can be integrated with both OPTIMA and OPTIMA-INV units, with up flow and down flow configurations. The corresponding series names are OPTIMA-DFC and OPTIMA-INV-DFC. The diagram showing the arrangement and principle for direct free cooling options is as follows:

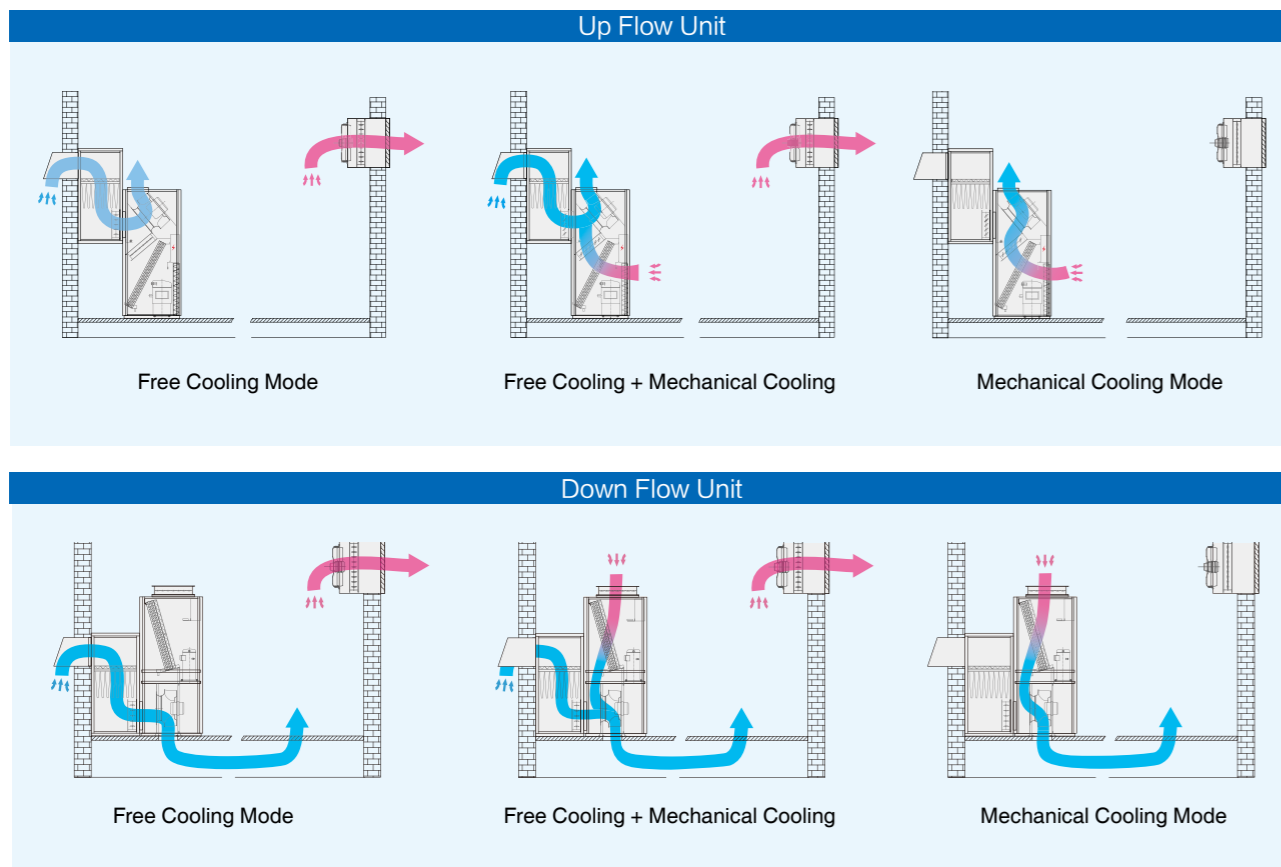

Both OPTIMA-DFC and OPTIMA-INV-DFC systems include mechanical (DX) cooling and free cooling modes, together with the intelligence to switch between the modes to ensure the most efficient operation. When utilizing direct free cooling, the DX system compressor stops, which has a significant impact on the energy consumption.

In recent years, energy-efficient data centers have attracted greater attention and many data centers are now able to achieve significant energy savings through both increasing the IT equipment tolerance temperatures and expanding the considered geographical scope to exploit direct free cooling (which is not only limited to regions of extreme cold). For the specific technical parameters of OPTIMA-DFC and OPTIMA-INV-DFC, please refer to P23 and P29 .

Group Control

Continuous and reliable operation of the air conditioning systems is critical for the successful operation of data center equipment. As a result of the high proportion of power consumed by such air conditioning systems, energy consumption has been a challenge faced by modern data centers. AIRSYS precision air conditioners aim to address this challenge, in part, through effective group control and rotation functions. Such control

philosophies ensure consistent room temperature and humidity, together with continuous reliable operation (generally, by the addition of a spare unit for redundancy) whilst minimizing the total power required for the air conditioning. Group control and rotation functions will also typically extend unit life and effectively save energy by improving the overall management of the system.

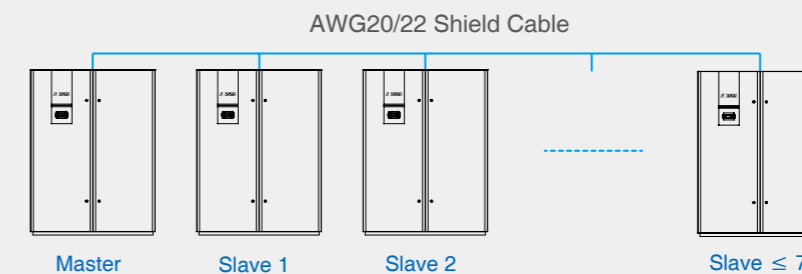

Remote Control & Network Monitoring

Networking and Monitoring of air conditioning equipment is typically a subsystem of a Building Management System (BMS) and provides centralized monitoring and management of all the air-conditioning equipment.

Thanks to years of experience in the production and application of precision air conditioning equipment, AIRSYS is able to provide a variety of monitoring systems ranging from simple SMS alarm monitoring to

the most sophisticated TERA cloud based GPRS wireless centralized monitoring system. There is a solution available to suit all sites and installations.

A given unit can be remote controlled or monitored via several means:

- 3 kinds of local direct cable connection
- 3 kinds of LAN network connection
- 4 kinds of wireless network connection

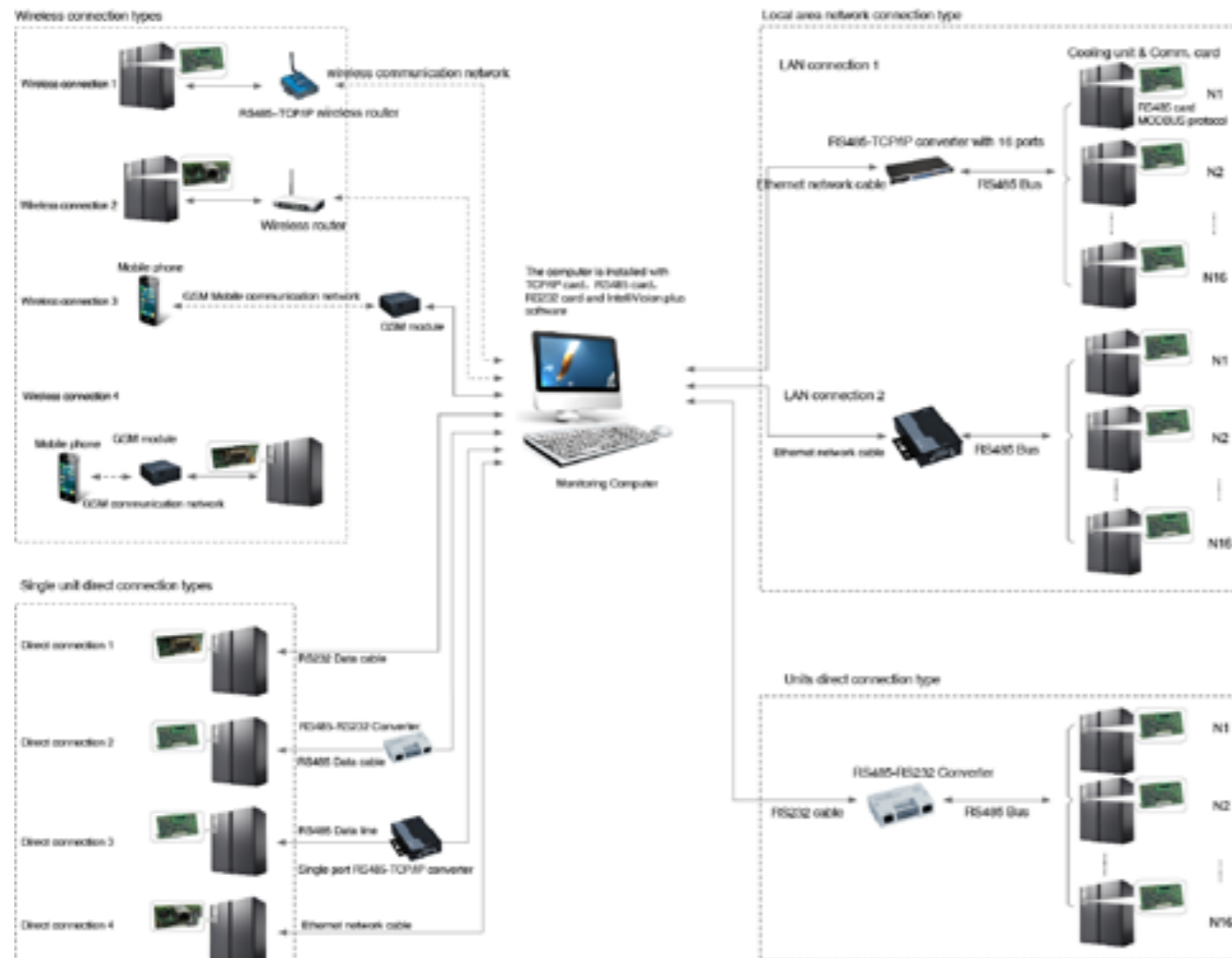

Unit configuration

OPTIMA Family Product Standard Configuration

Standard Configuration	OPTIMA				OPTIMA-INV	
	DXA	DXW	CW	CWD	DXA	DXW
Powder coated steel frame	●	●	●	●	●	●
Powder coated steel panel with inside thermal and acoustic insulation	●	●	●	●	●	●
EC centrifugal fan	●	●	●	●	●	●
Copper tube aluminum fin coil	●	●	●	●	●	●
Condensing water tray	●	●	●	●	●	●
Class G4 air filter	●	●	●	●	●	●
Temperature and RH sensor at return air inlet	●	●	●	●	●	●
Air pressure switch for supply fan protection	●	●	●	●	●	●
Microprocessor control	●	●	●	●	●	●
Electrical control panel	●	●	●	●	●	●
Stainless steel electric heater, various capacity available	●	●	●	●	●	●
Proportional controlled electrode type humidifier, various capacity available	●	●	●	●	●	●
Hermetic fixed frequency scroll compressor	●	●	—	—	—	—
Hermetic inverter scroll compressor	—	—	—	—	●	●
Rubber vibration absorber for compressor	●	●	—	—	●	●
Plate heat exchanger as water cooled condenser	—	●	—	—	—	●
External equalizer thermostatic expansion valve	●	●	—	—	—	—
Electric expansion valve	—	—	—	—	●	●
Sight glass	●	●	—	—	●	●
Filter dryer	●	●	—	—	●	●
Liquid receiver	●	●	—	—	●	●
High pressure transducer	●	●	—	—	●	●
Pressure switch for high/low pressure protection	●	●	—	—	●	●
Continuous control system for condensing pressure	●	●	—	—	●	●
Phase sequence protection relay for power supply	●	●	—	—	●	●
RS485 communication	●	●	—	—	●	●
Clock function	●	●	—	—	●	●
Motorized 2-way valve	—	●(1)	●	●	—	●(1)
Additional copper tube aluminum fin chilled water coil	—	—	—	●	—	—
Wooden packaging	●	●	●	●	●	●

Note: "●" standard configuration, "—" no option available.
(1) Need to choose when using cooling tower.

As well as the above standard configuration, OPTIMA(-INV)-FC/DC/DFC units also include the following standard configuration.

Standard Configuration	OPTIMA(-INV)-FC		OPTIMA(-INV)-DC		OPTIMA(-INV)-DFC			
	DXA	DXW	DXA	DXW	DXA	DXW	CW	CWD
Copper tube aluminum fin free cooling coil	●	●	—	—	—	—	—	—
Motorized 3-way valve	—	●	—	—	—	—	—	—
Copper tube aluminum fin chilled water cooling coil	—	—	●	●	—	—	—	—
Motorized 2-way valve	●	—	●	●	—	—	—	—
Fresh air inlet box	—	—	—	—	●	●	●	●

Note: "●" standard configuration, "—" no option available.

Options for OPTIMA Family Product

Option	OPTIMA				OPTIMA-INV	
	DXA	DXW	CW	CWD	DXA	DXW
Air pressure switch for clogged filter alarm	○	○	○	○	○	○
Motorized no-return damper for up flow unit	○	○	○	○	○	○
Supply air plenum for up flow unit	○	○	○	○	○	○
Supply air plenum for down flow unit	○	○	○	○	○	○
Backward air return for up flow unit	○	○	○	○	○	○
Installation support stand with adjustable legs	○	○	○	○	○	○
Supply air temperature sensor	○	○	○	○	○	○
Supply air static pressure sensor	○	○	○	○	○	○
Floor water leakage alarm kit	○	○	○	○	○	○
Additional floor water detector	○	○	○	○	○	○
Colored touch screen graphical user interface.	○	○	○	○	○	○
RS232 communication	○	○	○	○	○	○
RS485 communication	—	—	○	○	—	—
pCOweb communication card	○	○	○	○	○	○
GSM short message module	○	○	○	○	○	○
Remote display controller	○	○	○	○	○	○
Clock Card	—	—	○	○	—	—
Electronic expansion valve	○	○	—	—	—	—
Unit filled with R407C Refrigerant	○	○	—	—	—	—
Low temperature operation kit for outdoor temperature below -20°C (for DXA only)	○	—	—	—	○	—
Phase sequence protection relay for power supply	—	—	○	○	—	—
Motorized 3-way valve	—	—	○	○	—	—
Wooden box packing	○	○	○	○	○	○

Note: "○"option available, "—" no option available.

As well as the above options, OPTIMA(-INV)- DFC units also include air outlet box.

OPTIMA(-INV)-DFC Unit Options

Option	OPTIMA-DFC				OPTIMA(-INV)-DFC	
	DXA	DXW	CW	CWD	DXA	DXW
Air outlet box	○	○	○	○	○	○

Note: "○"option available.

Electric Heater/Humidifier Selection Sheet

	A1	A2	A3	A4	A5
Heat capacity(kW)	6	●	—	—	—
	9	○	●	—	—
	12	○	○	—	—
	13.5	—	○	●	—
	18	—	○	○	●
	27	—	—	—	○
	36	—	—	—	—
Humidification capacity(kg/h)	3	●	—	—	—
	5	○	●	—	—
	8	○	○	●	●
	10	—	—	○	○
	13	—	—	○	○
	15	—	—	○	○

Note: "●"means standard configuration, "○"means option, "—"means N/A.

Supply Air Plenum (Optional) Dimensions and Weight

Cabinet size		A1	A2	A3	A4	A5
Width	mm	875	1480	1750	2490	3095
Depth	mm	890	890	890	890	890
Height	mm	470	470	470	470	470
Weight	Kg	32	55	66	87	95

Technical Parameters

OPTIMA(-DFC/FC/DC).DXA

Unit Model		16E1A1	20E1A1	26E1A2	26E2A2	30E1A2	30E2A2	35E1A2	35E2A2	40E1A3	40E2A3	50E2A3	60E2A4	70E2A4	80E2A4	90E2A5	100E2A5		
Supply air scheme(1)		O/U																	
Cooling capacity																			
Total (2)	kW	18.9	22.0	28.5	29.0	31.9	30.5	37.6	36.6	45.2	46.6	55.1	65.3	74.5	84.6	90.7	103.4		
Sensible(2)	kW	18.3	20.7	26.2	26.6	29.3	27.8	35.3	33.3	41.2	44.3	51.1	59.9	71.4	79.4	86.1	97.7		
FC unit free cooling/DC unit cooling coil capacity																			
Total (3)	kW	16.5	21.8	30.1	-	33.6	-	37.6	-	-	42.4	50.3	55.9	67.3	78.5	93.4	104.6		
Sensible(3)	kW	15.3	19.8	27.4	-	30.9	-	34.2	-	-	39.0	45.8	51.4	61.2	71.4	85.9	95.2		
DFC unit free cooling capacity																			
Free cooling(4)	kW	9.7	10.7	15.0	15.0	16.2	16.2	16.2	16.2	21.3	21.3	23.0	30.1	32.4	35.5	41.5	47.1		
Free cooling(5)	kW	19.4	21.3	30.1	30.1	32.4	32.4	32.4	32.4	42.5	42.5	45.9	60.1	64.8	70.9	83.1	94.2		
Compressor		Hermetic scroll																	
Type		Hermetic scroll																	
Supply fan		Caseless backward EC centrifugal fan																	
Type		Caseless backward EC centrifugal fan																	
Qty. of fan	n.	1	1	1	1	1	1	1	1	2	2	2	3	3	3	3	3		
Air volume	m ³ /h	5750	6320	8900	8900	9600	9600	9600	9600	12600	12600	13600	17800	19200	21000	24600	27900		
External static (6)	Pa	Standard ESP is 75Pa, adjustment range is 50-300Pa																	
Air filter		G4/plate																	
Electric heater(7)		Stainless steel																	
Type		Stainless steel																	
Heating capacity	kW	6	6	9	9	9	9	9	9	13.5	13.5	13.5	18	18	18	18	18		
Working steps	n.	2	2	2	2	2	2	2	2	2	2	2	2	2	2	2	2		
Humidifier(8)		Electrode																	
Type		Electrode																	
Capacity	kg/h	3	3	5	5	5	5	5	5	8	8	8	8	8	8	8	8		
Air condenser(9)																			
Model*Qty(CME)(10)		CME5*1	CME8*1	CME10*1	CME4*2	CME10*1	CME5*2	CME15*1	CME8*2	CME15*1	CME8*2	CME10*2	CME10*2	CME15*2	CME15*2	CME20*2	CME20*2		
Model*Qty(CME)(11)		CME8*1	CME10*1	CME15*1	CME5*2	CME10*1	CME8*2	CME20*1	CME10*2	CME20*1	CME10*2	CME15*2	CME15*2	CME20*2	CME20*2	CME25*2	CME25*2		
Model*Qty(AMAE)		AMAE5*1	AMAE6*1	AMAE8*1	AMAE5*2	AMAE10*1	AMAE5*2	AMAE12*1	AMAE5*2	AMAE15*1	AMAE6*2	AMAE8*2	AMAE10*2	AMAE12*2	AMAE15*2	AMAE18*2	AMAE20*2		
Dry cooler(only available for FC unit)																			
Model		CMEH20	CMEH30	CMEH40	-	CMEH40	-	CMEH50	-	-	CMEH50	CMEH60	CMEH60	CMEH70	CMEH80	CMEH50	CMEH60		
Qty		1	1	1	-	1	-	1	-	-	1	1	1	1	1	2	2		
FC unit free cooling coil/DC unit chilled water coil																			
Water flow	m ³ /h	3.2	4.2	5.7	-	6.6	-	7.3	-	-	8.1	9.5	10.8	12.9	13.6	16.2	17.8		
Pressure drop	kPa	26.2	46.5	42.1	-	53.3	-	37.7	-	-	77.2	62.3	76.2	63.5	69.1	100.3	118.1		
DFC unit fresh air inlet box(12)																			
Model*Qty		S1*1	S1*1	S2*1	S2*1	S2*1	S2*1	S2*1	S2*1	S1*2	S1*2	S1*2	S1+S2	S1+S2	S1+S2	S2*2	S2*2		
DFC unit air outlet box(13)																			
Model*Qty		B*1	B*1	B*1	B*1	B*1	B*1	B*1	B*1	B*2	B*2	B*2	B*2	B*2	B*2	B*3	B*3		
Power supply		380V/3Ph/50Hz																	
Power source		380V/3Ph/50Hz																	
Unit max. operating power input	kW	14.3	15.8	20.0	15.8	22.5	17.9	24.3	18.9	33.1	25.9	29.4	36.7	39.0	42.4	47.2	49.2		
Unit max. operating current	A	25.5	27.6	35.0	26.1	38.5	34.3	43.3	34.9	57.5	43.1	54.8	60.7	72.8	79.0	91.2	93.4		
Unit piping connection																			
Humidifier water supply	in	1/2"	1/2"	1/2"	1/2"	1/2"	1/2"	1/2"	1/2"	1/2"	1/2"	1/2"	1/2"	1/2"	1/2"	1/2"	1/2"		
Condensing water drainage	in	3/4"	3/4"	3/4"	3/4"	3/4"	3/4"	3/4"	3/4"	3/4"	3/4"	3/4"	3/4"	3/4"	3/4"	3/4"	3/4"		
Refrigerant gas	mm	19	19	19	2x19	22	2x19	22	2x19	22	2x19	2x22	2x22	2x22	2x22	2x22	2x28		
Refrigerant liquid	mm	16	16	16	2x12	16	2x16	16	2x16	16	2x16	2x16	2x16	2x16	2x16	2x19	2x19		
Free cooling coil inlet/outlet water	in	1-1/4"	1-1/4"	1-1/4"	-	1-1/4"	-	1-1/4"	-	-	1-1/2"	1-1/2"	1-1/2"	2"	2"	2"	2"		
Unit external dimensions																			
Width	mm	875	875	1480	1480	1480	1480	1480	1480	1750	1750	1750	2490	2490	2490	3095	3095		
Depth	mm	890	890	890	890	890	890	890	890	890	890	890	890	890	890	890	890		
Height	mm	1960	1960	1960	1960	1960	1960	1960	1960	1960	1960	1960	1960	1960	1960	2050	2050		
Net weight																			
OPTIMA(-DFC)	kg	265	280	370	390	410	415	415	415	510	530	550	700	730	760	910	930		
OPTIMA-FC/DC	kg	296	316	410	-	461	-	466	-	-	595	615	772	817	847	1020	1040		
Wooden packaging dimension(W*D*H)																			
OPTIMA(-DFC)	mm	985x1025x2160			1590x1025x2160			1590x1025x2160			1860x1025x2160			2600x1025x2160			3205x1025x2250		
OPTIMA-FC/DC	mm	1085x1025x2160			1690x1025x2160			1690x1025x2160			1960x1025x2160			2700x1025x2160			3305x1025x2250		
Wooden packaging weight																			
OPTIMA(-DFC)	kg	350	365	480	500	520	525	525	525	635	655	675	855	885	915	1095	1115		
OPTIMA-FC/DC	kg	381	401	520	-	571	-	576	-	-	720	740	927	972	1002	1205	1225		

(1) O:Up flow; U:Down flow;

(2) Return air dry bulb temperature 24°C, RH50%, condensing temperature 47°C;

(3) Return air dry bulb temperature 24°C, RH50%, chilled water inlet/outlet 7°C/12°C;

(4) The cooling capacity@indoor temperature and outdoor temperature difference (ΔT) is 5°C compressor not operating;

(5) The cooling capacity@indoor temperature and outdoor temperature difference (ΔT) is 10°C, compressor not operating;

(6) For ESP over 300 Pa, Contact manufacturer;

(7) The default capacity, please refer to "electric heater selection sheet" for other capacity;

(8) The default capacity, please refer to " humidifier selection sheet" for other capacity;

(9) CME adopts AC fan, AMAE adopts EC fan, choose according to demand.

(10) Ambient temperature is lower than 40°C;

(11) Ambient temperature is higher than 40°C;

(12) Packaged individually, please refer to "OPTIMA-DFC Fresh Air Inlet Box" for specific parameters;

(13) Optional.

OPTIMA(-DFC/FC/DC).DXW

Unit Model		26E1A2	30E1A2	35E1A2	40E2A3	50E2A3	60E2A4	70E2A4	80E2A4	90E2A5	100E2A5
Supply air scheme(1)		O/U									
Cooling capacity											
Total (2)	kW	27.9	31.2	36.1	45.8	57.2	62.1	72.2	82.3	90.4	106.7
Sensible(2)	kW	25.4	28.4	32.9	41.7	52.1	56.5	65.7	74.9	82.3	97.1
FC unit free cooling/DC unit cooling coil capacity											
Total (3)	kW	30.1	33.6	37.6	42.4	50.3	55.9	67.3	78.5	93.4	104.6
Sensible(3)	kW	27.4	30.9	34.2	39.0	45.8	51.4	61.2	71.4	85.9	95.2
DFC unit free cooling capacity											
Free cooling(4)	kW	15.0	16.2	16.2	21.3	23.0	30.1	32.4	35.5	41.5	47.1
Free cooling(5)	kW	30.1	32.4	32.4	42.5	45.9	60.1	64.8	70.9	83.1	94.2
Compressor											
Type		Hermetic scroll					Hermetic scroll				
Supply fan											
Type		Caseless backward EC centrifugal fan					Caseless backward EC centrifugal fan				
Qty. of fan	n.	1	1	1	2	2	3	3	3	3	3
Air volume	m ³ /h	8900	9600	9600	12600	13600	17800	19200	21000	24600	27900
External static (6)	Pa	Standard ESP is 75Pa, adjustment range is 50-300Pa					Standard ESP is 75Pa, adjustment range is 50-300Pa				
Air filter		G4/plate									
Water condenser											
Water flow	m ³ /h	6.2	7.0	7.3	11.0	12.4	14.1	16.0	18.1	20.3	23.7
Pressure drop	kPa	28.6	30.7	26.0	46.4	44.3	44.8	46.3	48.4	34.3	36.7
Pressure drop(with valve)	kPa	44.6	50.7	47.5	63.4	62.8	58.3	61.3	69.9	51.8	55.2
Water volume	L	1.8	1.9	2.2	4.0	4.5	5.2	5.8	6.4	7.3	8.1
Dry cooler(7)											
Model		CMEH30	CMEH40	CMEH50	CMEH60	CMEH70	CMEH80	CMEH50	CMEH50	CMEH60	CMEH70
Qty	n.	1	1	1	1	1	1	2	2	2	2
FC unit free cooling coil/DC unit chilled water coil											
Water flow	m ³ /h	5.7	6.6	7.3	8.1	9.5	10.8	12.9	13.6	16.2	17.8
Pressure drop	kPa	42.1	53.3	37.7	77.2	62.3	76.2	63.5	69.1	100.3	118.1
DFC unit fresh air inlet box(8)											
Model*Qty		S2*1	S2*1	S2*1	S1*2	S1*2	S1+S2	S1+S2	S1+S2	S2*2	S2*2
DFC unit air outlet box(9)											
Model*Qty		B*1	B*1	B*1	B*2	B*2	B*2	B*2	B*2	B*3	B*3
Electric heater(10)											
Type		Stainless steel					Stainless steel				
Heating capacity	kW	9.0	9.0	9.0	13.5	13.5	18.0	18.0	18.0	18.0	18.0
Working steps	n.	2	2	2	2	2	2	2	2	2	2
Humidifier(10)											
Type		Electrode									
Capacity	kg/h	5	5	5	8	8	8	8	8	8	8
Power supply											
Power source		380V/3Ph/50Hz					380V/3Ph/50Hz				
Unit max. operating power input	kW	19.3	21.8	23.0	25.3	28.1	36.0	37.2	39.9	44.7	46.7
Unit max. operating current	A	31.6	35.1	37.3	40.1	48.0	57.3	59.5	67.0	79.2	81.4
Unit piping connection											
Humidifier water supply	in	1/2"	1/2"	1/2"	1/2"	1/2"	1/2"	1/2"	1/2"	1/2"	1/2"
Condensing water drainage	in	3/4"	3/4"	3/4"	3/4"	3/4"	3/4"	3/4"	3/4"	3/4"	3/4"
Chilling water inlet/outlet	in	1-1/4"	1-1/4"	1-1/4"	1-1/2"	1-1/2"	1-1/2"	2"	2"	2"	2"
FC/DC unit free cooling coil water inlet/outlet	in	1-1/4"	1-1/4"	1-1/4"	1-1/2"	1-1/2"	1-1/2"	2"	2"	2"	2"
Unit external dimensions											
Width	mm	1480	1480	1480	1750	1750	2490	2490	2490	3095	3095
Depth	mm	890	890	890	890	890	890	890	890	890	890
Height	mm	1960	1960	1960	1960	1960	1960	1960	1960	2050	2050
Net weight											
OPTIMA(-DFC)	kg	390	430	435	560	580	740	770	800	960	980
OPTIMA-FC/DC	kg	430	481	486	625	645	812	857	887	1070	1090
Wooden packaging dimension(W*D*H)											
OPTIMA(-DFC)	mm	1690x1025x2160			1960x1025x2160		1960x1025x2160		2700x1025x2160		3305x1025x2250
OPTIMA-FC/DC	mm	1690x1025x2160			1960x1025x2160		1960x1025x2160		2700x1025x2160		3305x1025x2250
Wooden packaging weight											
OPTIMA(-DFC)	kg	500	540	545	685	705	895	925	955	1145	1165
OPTIMA-FC/DC	kg	540	591	596	750	770	967	1012	1042	1255	1275

(1) O:Up flow; U:Down flow;

(2) Return air dry bulb temperature 24°C, RH50%, inlet/outlet chilling water temperature 30°C/35°C;

(3) Return air dry bulb temperature 24°C, RH50%, chilled water inlet/outlet 7°C/12°C;

(4) The cooling capacity@indoor temperature and outdoor temperature difference (ΔT) is 5°C compressor not operating;

(5) The cooling capacity@indoor temperature and outdoor temperature difference (ΔT) is 10°C, compressor not operating;

(6) For ESP over 300 Pa, Contact manufacturer;

(7) Option, choose when the user can't provide cooling water system;

(8) Packaged individually, please refer to "DFC Fresh Air Inlet Box" for specific parameters;

(9) Option;

(10) The default capacity, please refer to "electric heater/ humidifier selection sheet" for other capacity.

OPTIMA(-DFC).CW

Unit Model		20A1	30A1	40A2	45A2	55A3	65A3	80A4	100A4	120A5	140A5
Supply air scheme(1)		O/U									
Cooling capacity											
Total (2)	kW	24.8	30.3	40.8	47.7	55.8	66.5	80.5	100.2	112.1	134.5
Sensible(2)	kW	22.1	26.2	36.8	41.5	48.8	57.7	72.7	86.7	104.2	121.0
Total (3)	kW	19.3	23.8	31.5	37.4	43.5	50.0	62.7	76.1	92.8	112.9
Sensible(3)	kW	18.3	21.3	29.5	34.0	41.2	47.0	59.0	69.4	90.0	106.2
DFC unit free cooling capacity											
Free cooling(4)	kW	11.4	11.4	16.2	16.2	25.7	25.7	36.3	36.3	48.6	48.6
Free cooling(5)	kW	22.7	22.7	32.4	32.4	51.5	51.5	72.7	72.7	97.2	97.2
Cooling coil											
Water flow(2)	m ³ /h	4.2	5.2	6.8	8.1	9.1	11.0	13.6	16.8	18.3	21.8
Water flow(3)	m ³ /h	3.3	4.1	5.4	6.4	7.4	8.6	10.7	13.0	16.0	19.6
Water pressure drop(coil+valve)(2)	kPa	80.6	78.1	89.0	83.2	80.8	81.7	96.5	101.2	147.0	157.2
Water pressure drop(coil+valve)(3)	kPa	52.3	51.8	59.7	52.8	58.7	57.6	65.1	76.4	109.7	110.9
Supply fan											
Type	Caseless backward EC centrifugal fan										
Qty. of fan	n.	1	1	1	1	2	2	3	3	3	3
Air volume	m ³ /h	6750	6750	9600	9600	15300	15300	21600	21600	28900	28900
External static pressure (ESP) (6)	Pa	Standard ESP is 75Pa, adjustment range is 50-300Pa									
DFC unit fresh air inlet box(7)											
Model*Qty		S1*1	S1*1	S2*1	S2*1	S1*2	S1*2	S1+S2	S1+S2	S2*2	S2*2
DFC unit air outlet box(8)											
Model*Qty		B*1	B*1	B*1	B*1	B*2	B*2	B*2	B*2	B*3	B*3
Electric heater(9)											
Type	Stainless steel										
Heating capacity	kW	6	6	9.0	9.0	13.5	13.5	18	18	18	18
Working steps	n.	2	2	2	2	2	2	2	2	2	2
Humidifier(9)											
Type	Electrode										
Capacity	kg/h	3	3	5	5	8	8	8	8	8	8
Power supply											
Power source	380V/3Ph/50Hz										
Unit max. operating power input(10)	kW	11.2	11.3	15.0	15.3	22.9	23.5	29.1	30.0	30.3	31.5
Unit max. operating current(10)	A	17.1	17.3	22.4	22.9	35.2	35.8	44.9	45.8	46.4	47.6
Unit piping connection											
Humidifier water supply	in	1/2"	1/2"	1/2"	1/2"	1/2"	1/2"	1/2"	1/2"	1/2"	1/2"
Condensing water drainage	in	3/4"	3/4"	3/4"	3/4"	3/4"	3/4"	3/4"	3/4"	3/4"	3/4"
Chilling water inlet/outlet	in	1 1/4"	1 1/4"	1 1/4"	1 1/4"	1 1/2"	1 1/2"	2"	2"	2 1/2"	2 1/2"
Unit external dimensions											
Width	mm	875	875	1480	1480	1750	1750	2490	2490	3095	3095
Depth	mm	890	890	890	890	890	890	890	890	890	890
Height	mm	1960	1960	1960	1960	1960	1960	1960	1960	2050	2050
Net weight	kg	310	335	380	410	470	510	550	575	660	690
Wooden packaging dimensions and weight											
W*D*H	mm	1085×1025×2160		1690×1025×2160		1960×1025×2160		2700×1025×2160		3305×1025×2250	
Weight	kg	395	420	490	520	595	635	705	730	845	875

- (1) O:Up flow; U:Down flow;
 (2) Return air dry bulb temperature 24°C,RH50%, inlet/outlet chilled water temperature 7°C/12°C;
 (3) Return air dry bulb temperature 28°C,RH40%, inlet/outlet chilled water temperature 10°C/15°C;
 (4) The cooling capacity@indoor temperature and outdoor temperature difference (ΔT) is 5°C compressor not operating;
 (5) The cooling capacity@indoor temperature and outdoor temperature difference (ΔT) is 10°C, compressor not operating;
 (6) For ESP over 300 Pa, Contact manufacturer;
 (7) Packaged individually, please refer to "DFC Fresh Air Inlet Box" for specific parameters;
 (8) Option;
 (9) The default capacity, please refer to "electric heater/ humidifier selection sheet" for other capacity;
 (10) Max. operating power input and current input: as above spec sheet, under the condition of dehumidification plus 100% electric reheat.

OPTIMA(-DFC).CWD

Unit Model		20A1	30A1	40A2	45A2	55A3	65A3	80A4	100A4	120A5	140A5
Supply air scheme(1)		O/U									
Cooling capacity(2)											
Total (3)	kW	24.8	30.3	40.8	47.7	55.8	66.5	80.5	100.2	112.1	134.5
Sensible(3)	kW	22.1	26.2	36.8	41.5	48.8	57.7	72.7	86.7	104.2	121.0
Total (4)	kW	19.3	23.8	31.5	37.4	43.5	50.0	62.7	76.1	92.8	112.9
Sensible(4)	kW	18.3	21.3	29.5	34.0	41.2	47.0	59.0	69.4	90.0	106.2
DFC unit free cooling capacity											
Free cooling(5)	kW	11.4	11.4	16.2	16.2	25.7	25.7	36.3	36.3	48.6	48.6
Free cooling(6)	kW	22.7	22.7	32.4	32.4	51.5	51.5	72.7	72.7	97.2	97.2
Cooling coil											
Water flow(3)	m ³ /h	4.2	5.2	6.8	8.1	9.1	11.0	13.6	16.8	18.3	21.8
Water flow(4)	m ³ /h	3.3	4.1	5.4	6.4	7.4	8.6	10.7	13.0	16.0	19.6
Water pressure drop(coil+valve)(3)	kPa	80.6	78.1	89.0	83.2	80.8	81.7	96.5	101.2	147.0	157.2
Water pressure drop(coil+valve)(4)	kPa	52.3	51.8	59.7	52.8	58.7	57.6	65.1	76.4	109.7	110.9
Supply fan											
Type	Caseless backward EC centrifugal fan										
Qty. of fan	n.	1	1	1	1	2	2	3	3	3	3
Air volume	m ³ /h	6750	6750	9600	9600	15300	15300	21600	21600	28900	28900
External static pressure (ESP) (7)	Pa	Standard ESP is 75Pa, adjustment range is 50-300Pa									
DFC unit fresh air inlet box(8)											
Model*Qty		S1*1	S1*1	S2*1	S2*1	S1*2	S1*2	S1+S2	S1+S2	S2*2	S2*2
DFC unit air outlet box(9)											
Model*Qty		B*1	B*1	B*1	B*1	B*2	B*2	B*2	B*2	B*3	B*3
Electric heater(10)											
Type	Stainless steel										
Heating capacity	kW	6	6	9.0	9.0	13.5	13.5	18	18	18	18
Working steps	n.	2	2	2	2	2	2	2	2	2	2
Humidifier(10)											
Type	Electrode										
Capacity	kg/h	3	3	5	5	8	8	8	8	8	8
Power supply											
Power source	380V/3Ph/50Hz										
Unit max. operating power input(11)	kW	11.2	11.3	15.0	15.3	22.9	23.5	29.1	30.0	30.3	31.5
Unit max. operating current(11)	A	17.1	17.3	22.4	22.9	35.2	35.8	44.9	45.8	46.4	47.6
Unit piping connection											
Humidifier water supply	in	1/2"	1/2"	1/2"	1/2"	1/2"	1/2"	1/2"	1/2"	1/2"	1/2"
Condensing water drainage	in	3/4"	3/4"	3/4"	3/4"	3/4"	3/4"	3/4"	3/4"	3/4"	3/4"
Chilling water inlet/outlet	in	1 1/4"	1 1/4"	1 1/4"	1 1/4"	1 1/2"	1 1/2"	2"	2"	2 1/2"	2 1/2"
Unit external dimensions											
Width	mm	875	875	1480	1480	1750	1750	2490	2490	3095	3095
Depth	mm	890	890	890	890	890	890	890	890	890	890
Height	mm	1960	1960	1960	1960	1960	1960	1960	1960	2050	2050
Net weight	kg	327	356	408	448	504	556	600	642	730	785
Wooden packaging dimensions and weight											
W*D*H	mm	1085×1025×2160		1690×1025×2160		1960×1025×2160		2700×1025×2160		3305×1025×2250	
Weight	kg	412	441	518	558	629	681	755	802	915	970

- (1) O:Up flow; U:Down flow;
 (2) Single cooling coil offers. Under the standard condition, the total cooling capacity will increase by 45% when two coils work at the same time;
 (3)Return air dry bulb temperature 24°C,RH50%, inlet/outlet chilled water temperature 7°C/12°C;
 (4)Return air dry bulb temperature 28°C,RH40%, inlet/outlet chilled water temperature 10°C/15°C;
 (5)The cooling capacity@indoor temperature and outdoor temperature difference (ΔT) is 5°C compressor not operating;
 (6)The cooling capacity@indoor temperature and outdoor temperature difference (ΔT) is 10°C, compressor not operating;
 (7) For ESP over 300 Pa, Contact manufacturer;
 (8) Packaged individually, please refer to "DFC Fresh Air Inlet Box" for specific parameters;
 (9) Option;
 (10)The default capacity, please refer to "electric heater/ humidifier selection sheet" for other capacity;
 (11) Max. operating power input and current input: as above spec sheet, under the condition of dehumidification plus 100% electric reheat.

OPTIMA-INV(-DFC/FC/DC).DXA

Unit Model		16V1A1	22V1A2	30V1A2	35V2A3	45V2A3	55V2A3	60V2A4	70V2A4	80V2A4	90V2A5	110V2A5
Supply air scheme(1)		O/U										
Cooling capacity												
Total (2)	kW	18.2	25.1	33.2	40.6	51.9	60.7	71.2	80.6	91.3	101.5	123.6
Sensible(2)	kW	16.7	23.3	30.2	37.4	47.2	55.3	65.5	73.3	82.2	91.4	111.2
FC unit free cooling/DC unit cooling coil capacity												
Total (3)	kW	17.1	23.5	34.5	37.8	41.7	57.1	63.6	75.3	84.4	93.4	114.6
Sensible(3)	kW	15.6	21.4	31.4	35.5	39.2	53.7	59.8	70.8	79.3	87.8	107.7
DFC unit free cooling capacity												
Free cooling(4)	kW	10.7	15	16.2	21.3	23	24.7	30.1	32.4	35.5	41.5	47.1
Free cooling(5)	kW	21.3	30.1	32.4	42.5	45.9	59.5	60.1	64.8	70.9	83.1	94.2
Compressor(6)												
Type		Hermetic inverter scroll										
Supply fan												
Type		Caseless backward EC centrifugal fan										
Qty. of fan	n.	1	1	1	2	2	2	3	3	3	3	3
Air volume	m ³ /h	5750	8900	9600	12600	12600	13600	17800	19200	21000	24600	27900
External static (7)	Pa	Standard ESP is 75Pa, adjustment range is 50~300Pa										
Air filter												
		G4/plate										
Electric heater(8)												
Type		Stainless steel										
Heating capacity	kW	6	9	9	13.5	13.5	13.5	18	18	18	18	18
Working steps	n.	2	2	2	2	2	2	2	2	2	2	2
Humidifier(8)												
Type		Electrode										
Capacity	kg/h	3	5	5	8	8	8	8	8	8	8	8
Power input	kW	2.3	3.8	3.8	5.9	5.9	5.9	5.9	5.9	5.9	5.9	5.9
Air condenser(9)												
Model*Qty		AMAE6*1	AMAE8*1	AMAE10*1	AMAE6*2	AMAE8*2	AMAE8*2	AMAE10*2	AMAE12*2	AMAE15*2	AMAE18*2	AMAE20*2
Model*Qty		CMEG8*1	CMEG10*1	CMEG10*1	CMEG8*1	CMEG10*2	CMEG10*2	CMEG10*2	CMEG15*2	CMEG20*2	CMEG20*2	CMEG20*2
Dry cooler(only available for FC unit)												
Model		CMEH20	CMEH30	CMEH40	CMEH50	CMEH60	CMEH70	CMEH80	CMEH50	CMEH50	CMEH60	CMEH70
Qty		1	1	1	1	1	1	1	2	2	2	2
FC unit free cooling coil/DC unit chilled water coil												
Water flow	m ³ /h	3.2	5.7	7.3	7.8	8.1	9.5	10.8	12.9	13.6	16.2	17.8
Pressure drop	kPa	26.2	42.1	37.7	68.3	77.2	62.3	76.2	63.5	69.1	100.3	118.1
DFC unit fresh air inlet box(10)												
Model*Qty		S1*1	S2*1	S2*1	S1*2	S1*2	S1*2	S1+S2	S1+S2	S1+S2	S2*2	S2*2
DFC unit air outlet box(11)												
Model*Qty		B*1	B*1	B*1	B*2	B*2	B*2	B*2	B*2	B*2	B*3	B*3
Power supply												
Power source		380V/3Ph/50Hz										
Unit max. operating power input	kW	17.2	22.6	25.7	27.2	29.2	32.0	38.0	39.0	43.5	47.5	49.0
Unit max. operating current	A	33.2	42.7	47.5	45.5	53.1	54.4	67.6	69.8	76.3	79.3	86.4
Unit piping connection												
Humidifier water supply	in	1/2"										
Condensing water drainage	in	3/4"										
Refrigerant gas	mm	19	19	22	2x19	2x19	2x19	2x22	2x22	2x22	2x22	2x28
Refrigerant liquid	mm	16	16	16	2x16	2x16	2x16	2x16	2x16	2x16	2x19	2x19
Free cooling coil inlet/outlet water	in	1-1/4"	1-1/4"	1-1/4"	1-1/2"	1-1/2"	1-1/2"	1-1/2"	2"	2"	2"	2"
Unit external dimensions												
Width	mm	875	1480	1480	1750	1750	1750	2490	2490	2490	3095	3095
Depth	mm	890	890	890	890	890	890	890	890	890	890	890
Height	mm	1960	1960	1960	1960	1960	1960	1960	1960	1960	2050	2050
Net weight												
OPTIMA-INV(-DFC)	kg	348	440	475	710	750	790	960	1010	1150	1270	1350
OPTIMA-INV-FC/DC	kg	375	490	510	750	790	830	1080	1130	1220	1420	1510
Wooden packaging dimension												
OPTIMA-INV(-DFC)	mm	985x1025x2160	1590x1025x2160	1860x1025x2160				2600x1025x2160			3205x1025x2250	
OPTIMA-INV-FC/DC	mm	1085x1025x2160	1690x1025x2160	1960x1025x2160				2700x1025x2160			3305x1025x2250	
Wooden packaging weight												
OPTIMA-INV(-DFC)	kg	433	550	585	835	875	915	1115	1165	1305	1455	1535
OPTIMA-INV-FC/DC	kg	460	600	620	875	915	955	1235	1285	1375	1605	1695

- (1) O:Up flow; U:Down flow;
- (2) Return air dry bulb temperature 24°C, RH50%, condensing temperature 47°C, inverter compressor under economic speed;
- (3) Return air dry bulb temperature 24°C, RH50%, inlet/outlet chilled water temperature 7°C/12°C;
- (4) The cooling capacity@indoor temperature and outdoor temperature difference (ΔT) is 5°C compressor not operating;
- (5) The cooling capacity@indoor temperature and outdoor temperature difference (ΔT) is 10°C, compressor not operating;
- (6) For dual refrigerating circuit units, including a hermetic fixed frequency scroll compressor except for a hermetic inverter scroll compressor;
- (7) For ESP over 300 Pa, Contact manufacturer;
- (8) The default capacity, please refer to "electric heater/ humidifier selection sheet" for other capacity;
- (9) CME adopts AC fan, AMAE adopts EC fan, choose according to demand;
- (10) Packaged individually, please refer to "DFC Fresh Air Inlet Box" for specific parameters;
- (11) Optional.

OPTIMA-INV(-DFC/FC/DC).DXW

Unit Model		22V1A2	30V1A2	35V2A3	45V2A3	55V2A3	60V2A4	70V2A4	80V2A4	90V2A5	110V2A5	
Supply air scheme(1)		O/U										
Cooling capacity												
Total (2)	kW	25.9	35.3	42.5	53.9	62.0	73.2	83.9	94.5	103.1	126.9	
Sensible(2)	kW	23.8	32.5	40.4	50.7	56.5	66.6	75.5	85.1	92.8	114.2	
FC unit free cooling/DC unit cooling coil capacity												
Total (3)	kW	23.5	34.5	37.8	41.7	57.1	63.6	75.3	84.4	93.4	114.6	
Sensible(3)	kW	21.4	31.4	35.5	39.2	53.7	59.8	70.8	79.3	87.8	107.7	
DFC unit free cooling capacity												
Free cooling(4)	kW	15.0	16.2	21.3	23.0	24.7	30.1	32.4	35.5	41.5	47.1	
Free cooling(5)	kW	30.1	32.4	42.5	45.9	59.5	60.1	64.8	70.9	83.1	94.2	
Compressor(6)												
Type		Hermetic inverter scroll										
Supply fan												
Type		Caseless backward EC centrifugal fan										
Qty. of fan	n.	1	1	2	2	2	3	3	3	3	3	
Air volume	m ³ /h	8900	9600	12600	12600	13600	17800	19200	21000	24600	27900	
External static (7)	Pa	Standard ESP is 75Pa, adjustment range is 50~300Pa										
Air filter												
		G4/plate										
Water condenser												
Water flow	m ³ /h	6.2	7.3	9.6	11.7	13.6	14.1	16.0	18.1	20.3	23.7	
Pressure drop	kPa	28.6	26.0	41.3	47.5	45.5	44.8	46.3	48.4	34.3	36.7	
Pressure drop(with valve)	kPa	44.6	47.5	56.3	64.3	63.4	58.3	61.3	69.9	51.8	55.2	
Water volume	L	1.8	2.2	3.2	4.2	4.7	5.2	5.8	6.4	7.3	8.1	
Dry cooler(8)												
Model		CMEH30	CMEH40	CMEH50	CMEH60	CMEH70	CMEH80	CMEH50	CMEH50	CMEH60	CMEH70	
Qty		1	1	1	1	1	1	2	2	2	2	
FC unit free cooling coil/DC unit chilled water coil												
Water flow	m ³ /h	5.7	7.3	7.8	8.1	9.5	10.8	12.9	13.6	16.2	17.8	
Pressure drop	kPa	42.1	37.7	68.3	77.2	62.3	76.2	63.5	69.1	100.3	118.1	
DFC unit fresh air inlet box(9)												
Model*Qty		S2*1	S2*1	S1*2	S1*2	S1*2	S1+S2	S1+S2	S1+S2	S2*2	S2*2	
DFC unit air outlet box(10)												
Model*Qty		B*1	B*1	B*2	B*2	B*2	B*2	B*2	B*2	B*3	B*3	
Electric heater(11)												
Type		Stainless steel										
Heating capacity	kW	9	9	13.5	13.5	13.5	18	18	18	18	18	
Working steps	n.	2	2	2	2	2	2	2	2	2	2	
Humidifier(11)												
Type		Electrode										
Capacity	kg/h	5	5	8	8	8	8	8	8	8	8	
Power input	kW	3.8	3.8	5.9	5.9	5.9	5.9	5.9	5.9	5.9	5.9	
Power supply												
Power source		380V/3Ph/50Hz										
Unit max. operating power input	kW	22.6	25.7	27.2	29.2	32.0	38.0	39.0	43.5	47.5	49.0	
Unit max. operating current	A	42.7	47.5	45.5	53.1	54.4	67.6	69.8	76.3	79.3	86.4	
Unit piping connection												
Humidifier water supply	in	1/2"										
Condensing water drainage	in	3/4"										
Chilling water inlet/outlet	in	1-1/4"	1-1/4"	1-1/2"	1-1/2"	1-1/2"	1-1/2"	2"	2"	2"	2"	
FC/DC unit free cooling coil water inlet/outlet	in	1-1/4"	1-1/4"	1-1/2"	1-1/2"	1-1/2"	1-1/2"	2"	2"	2"	2"	
Unit external dimensions												
Width	mm	1480	1480	1750	1750	1750	2490	2490	2490	3095	3095	
Depth	mm	890	890	890	890	890	890	890	890	890	890	
Height	mm	1960	1960	1960	1960	1960	1960	1960	1960	2050	2050	
Net weight												
OPTIMA-INV(-DFC)	kg	395	490	510	750	810	860	1080	1130	1250	1430	
OPTIMA-INV-FC/DC	kg	520	540	790	830	875	1120	1160	1280	1470	1590	
Wooden packaging dimension												
OPTIMA-INV(-DFC)	mm	1690x1025x2160	1960x1025x2160				2700x1025x2160			3305x1025x2250		
OPTIMA-INV-FC/DC	mm	1690x1025x2160	1960x1025x2160				2700x1025x2160			3305x1025x2250		
Wooden packaging weight												
OPTIMA-INV(-DFC)	kg	600	620	875	935	985	1235	1285	1405	1615	1725	
OPTIMA-INV-FC/DC	kg	630	650	915	955	1000	1275	1315	1435	1655	1775	

- (1) O:Up flow; U:Down flow;
- (2) Return air dry bulb temperature 24°C, RH50%, inlet/outlet chilled water temperature 30°C/35°C, inverter compressor at economic speed;
- (3) Return air dry bulb temperature 24°C, RH50%, inlet/outlet chilled water temperature 7°C/12°C;
- (4) The cooling capacity@indoor temperature and outdoor temperature difference (ΔT) is 5°C compressor not operating;
- (5) The cooling capacity@indoor temperature and outdoor temperature difference (ΔT) is 10°C, compressor not operating;
- (6) For dual refrigerating circuit units, including a hermetic fixed frequency scroll compressor except for a hermetic inverter scroll compressor;
- (7) For ESP over 300 Pa, Contact manufacturer;
- (8) Option, choose when the user can't provide cooling water system;
- (9) Packaged individually, please refer to "DFC Fresh Air Inlet Box" for specific parameters;
- (10) Optional;
- (11) The default capacity, please refer to "electric heater/ humidifier selection sheet" for other capacity.

DFC Fresh Air Inlet Box

Model		S1	S2
G4 Panel air filter			
Size	mm	825*545*10	717*545*10
Qty	n.	1	2
F7 Bag air filter			
Size	mm	828*545*46	717*545*46
Qty	n.	1	2
Air inlet/outlet			
Length	mm	732	1320
Width	mm	410	410
Unit external dimensions and Weight			
Width	mm	870	1480
Depth	mm	680	680
Height	mm	1450	1450
Weight	kg	90	143
Wooden packaging dimensions and Weight			
Width	mm	1020	1630
Depth	mm	820	820
Height	mm	1650	1650
Weight	kg	164	234

AMAE air cooled condenser

Model		AMAE5	AMAE6	AMAE8	AMAE10	AMAE12	AMAE15	AMAE18	AMAE20
Capacity (1)									
	kW	24.2	29.7	36.2	41.3	50.7	57.2	62.4	74.3
Fan									
Fan qty.	No.	1	1	1	1	2	2	2	2
Air flow rate	m ³ /h	12500	11600	11800	11500	23500	22000	23400	22600
Input power	kW	0.63	0.63	0.63	0.63	1.26	1.26	1.26	1.26
Input current	A	2.8	2.8	2.8	2.8	5.6	5.6	5.6	5.6
Connection tube size									
Gas pipe	mm	19	19	19	22	22	22	22	28
Liquid pipe	mm	16	16	16	16	16	16	19	19
Unit external dimensions and Weight									
Length	mm	1365	1365	1665	1665	1985	1985	2785	2785
Width	mm	620	620	620	620	620	620	620	620
Height	mm	1080	1080	1080	1080	1080	1080	1080	1080
Weight	kg	60	73	92	109	130	139	163	177
Wooden packaging dimensions and Weight									
Width	mm	1480	1480	1780	1780	2100	2100	2900	2900
Depth	mm	755	755	755	755	755	755	755	755
Height	mm	1235	1235	1235	1235	1235	1235	1235	1235
Weight	kg	118	131	150	167	188	197	231	245

(1)The capacity is rated at entering air temperature 35°C and condensing temperature 50°C condition.

CME air cooled condenser

Model		CME5	CME8	CME10	CME15	CME20	CME25
		CMEG5	CMEG8	CMEG10	CMEG15	CMEG20	CMEG25
Capacity (1)							
	kW	20.5	29.6	35.4	47.6	67.4	73.1
Fan							
Fan qty.	No.	1	1	1	2	2	2
Air flow rate	m ³ /h	5600	10100	9700	11600	20100	19100
Input power	kW	0.37	0.63	0.63	0.74	1.26	1.26
Input current	A	1.7	3.0	3.0	3.4	6.0	6.0
Connection tube size							
Gas pipe	mm	19	22	22	22	28	35
Liquid pipe	mm	12	16	16	19	19	22
Unit external dimensions and Weight							
Length	mm	1140	1340	1340	1540	2400	2400
Width	mm	475	620	620	620	630	630
Height	mm	770	1070	1070	1070	1135	1135
Weight	kg	47	95	110	130	155	185
Wooden packaging dimensions and Weight							
Width	mm	1225	1455	1455	1655	2515	2515
Depth	mm	610	755	755	755	765	765
Height	mm	925	1225	1225	1225	1290	1290
Weight	kg	82	145	160	180	205	235

(1)The capacity is rated at entering air temperature 35°C and condensing temperature 50°C condition.

CMEH Dry Cooler

Unit model		CMEH20	CMEH30	CMEH40	CMEH50	CMEH60	CMEH70	CMEH80
Capacity (1)								
	kW	23.2	31.2	45.3	56.7	61.5	75.2	83.1
Water flow								
	m ³ /h	3.5	5.2	6.2	9.3	10.2	10.6	11.8
Pressure drop								
	kpa	71.1	68.2	58.7	57.6	69.1	72.3	78.5
Fan								
Air flow rate	m ³ /h	12100	11200	22800	23200	21800	33600	32400
Fan Qty.	n.	1	1	2	2	2	3	3
Input power	kW	0.75	0.75	1.5	1.5	1.5	2.3	2.3
Input current	A	3.3	3.3	6.6	6.6	6.6	10.1	10.1
Connection tube size								
Water inlet pipe Φ	in	1-1/4"	1-1/4"	1-1/2"	1-1/2"	1-1/2"	2"	2"
Water outlet pipe Φ	in	1-1/4"	1-1/4"	1-1/2"	1-1/2"	1-1/2"	2"	2"
Unit external dimensions and Weight								
Length	mm	1350	1350	1980	2700	2700	3580	3580
Width	mm	620	620	620	620	620	620	620
Height	mm	1070	1070	1120	1120	1120	1120	1120
Weight	kg	95	115	145	175	195	235	255
Wooden packaging dimensions and Weight								
Width	mm	1470	1470	2100	2710	2810	3700	3700
Depth	mm	885	885	885	885	885	885	885
Height	mm	1240	1240	1290	1290	1290	1290	1290
Weight	kg	145	165	195	235	245	320	340

(1) The capacity is rated at entering air temperature 35°C and inlet water temperature 45°C condition.

PUG Pump Group Box

Unit model		PUG5	PUG10	PUG15	PUG20	PUG25
Water flow	m ³ /h	5.6	9.5	15.2	20.2	25.3
Pressure	m	26	27	28	26	26
Pump Qty.	n.	2	2	2	2	2
Input power	kW	1.1	1.5	2.2	3	4
Input current	A	2.6	3.1	4.9	6.3	8.1
Connection tube size						
Water inlet pipe Φ	in	1-1/4"	1-1/2"	2"	2"	2"
Water outlet pipe Φ	in	1-1/4"	1-1/2"	2"	2"	2"
Unit external dimensions and Weight						
Length	mm	1390	1390	1390	1390	1390
Width	mm	750	750	750	750	750
Height	mm	1050	1050	1050	1050	1050
Weight	kg	115	120	150	163	180

(1) Each unit is equipped with two pumps, use one and the other one stand by. Above parameters is rated at signal pump works.

Supply Air Plenum (Option)

Cabinet Size		A1	A2	A3	A4	A5
Width	mm	875	1480	1750	2490	3095
Depth	mm	890	890	890	890	890
Height	mm	470	470	470	470	470
Weight	kg	32	55	66	87	95

Unit Dimension Drawing

A1 Unit Cabinet Dimension Drawing for Up Flow Unit

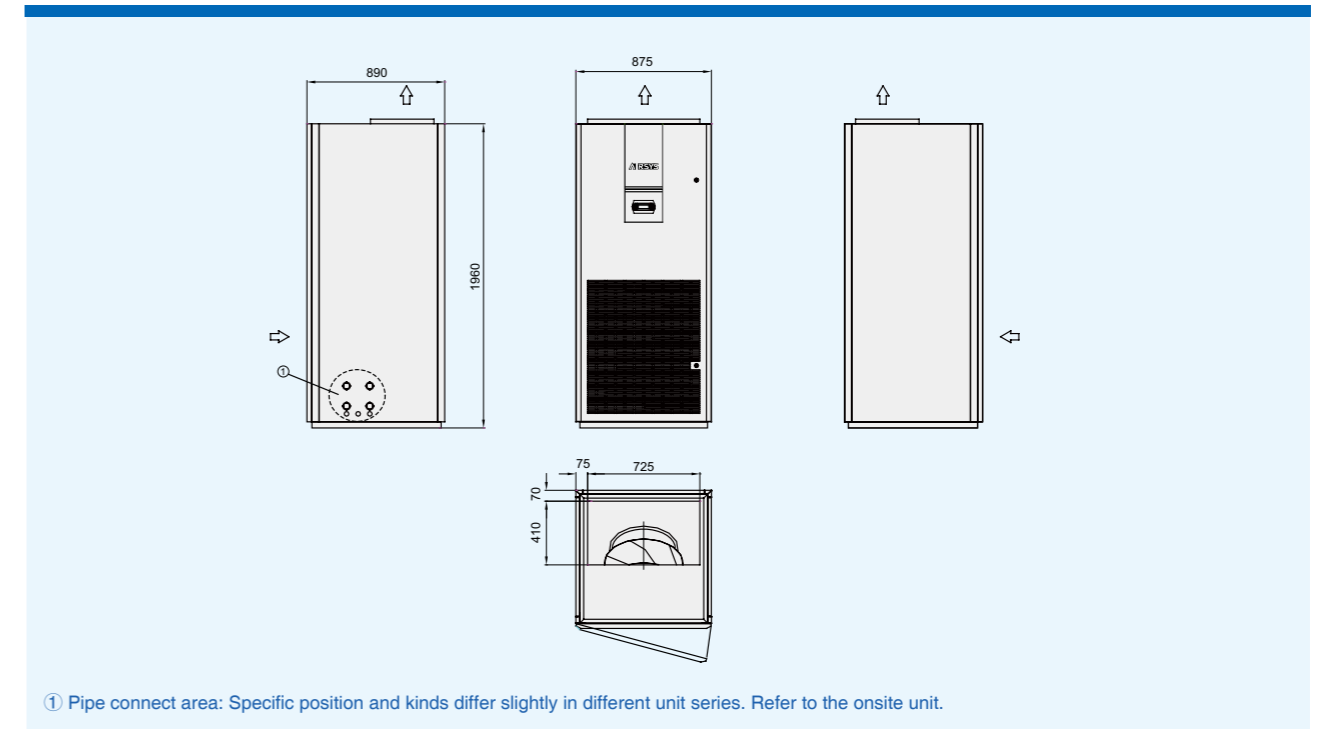

A1 Unit Cabinet Dimension Drawing for Under Flow Unit

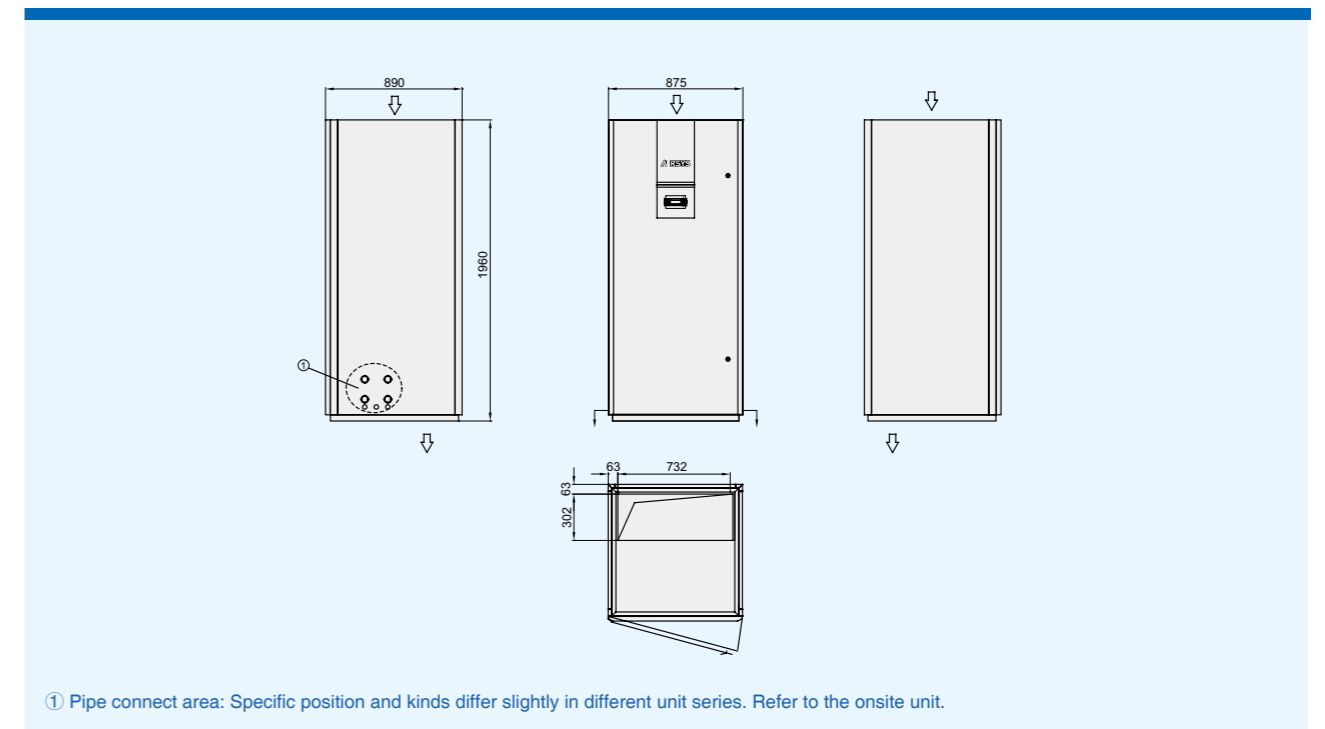

A2 Unit Cabinet Dimension Drawing for Up Flow Unit

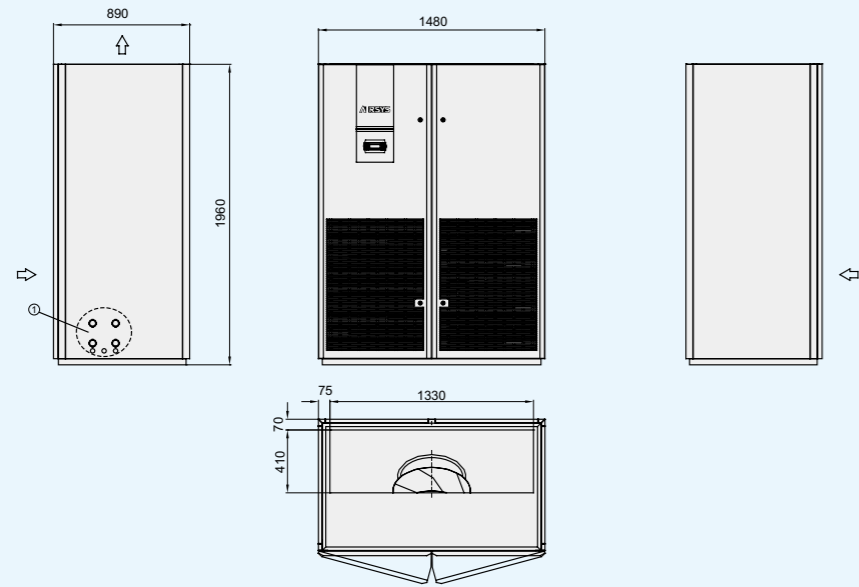

① Pipe connect area: Specific position and kinds differ slightly in different unit series. Refer to the onsite unit.

A3 Unit Cabinet Dimension Drawing for Up Flow Unit

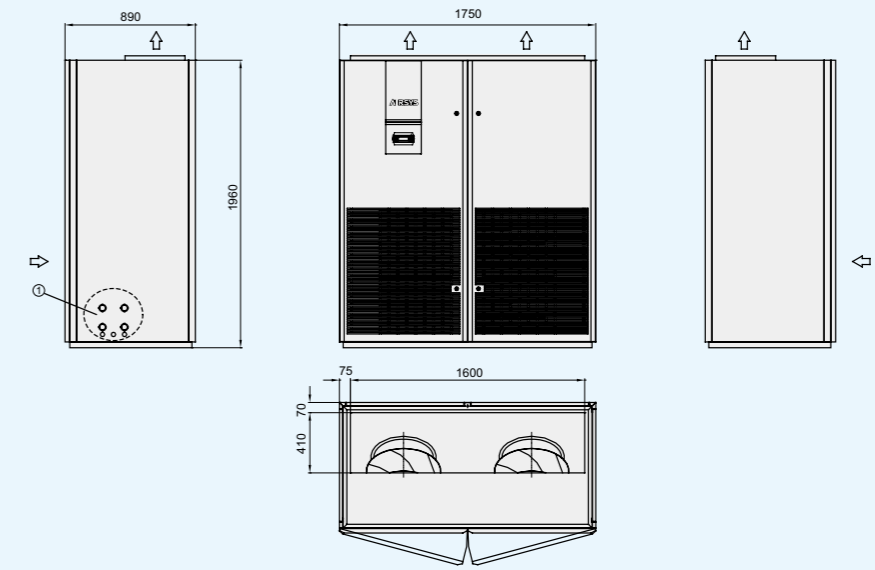

① Pipe connect area: Specific position and kinds differ slightly in different unit series. Refer to the onsite unit.

A2 Unit Cabinet Dimension Drawing for Under Flow Unit

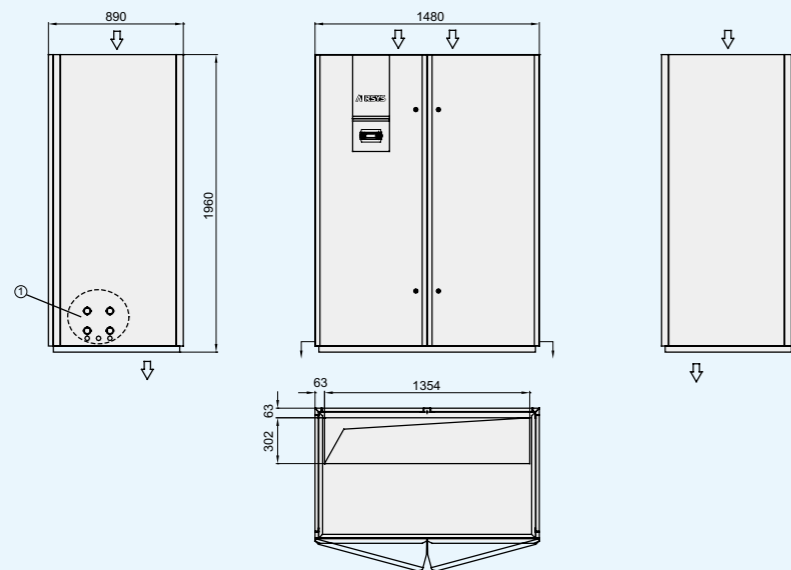

① Pipe connect area: Specific position and kinds differ slightly in different unit series. Refer to the onsite unit.

A3 Unit Cabinet Dimension Drawing for Under Flow Unit

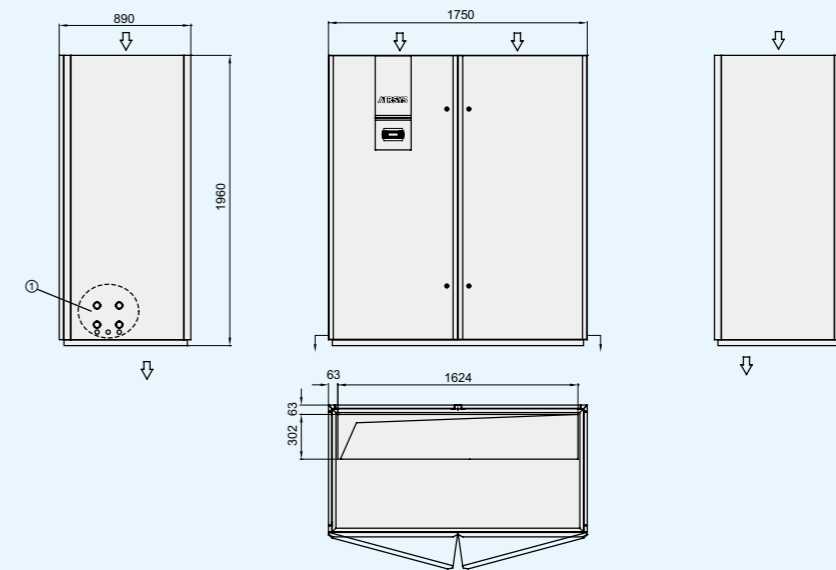

① Pipe connect area: Specific position and kinds differ slightly in different unit series. Refer to the onsite unit.

A4 Unit Cabinet Dimension Drawing for Up Flow Unit

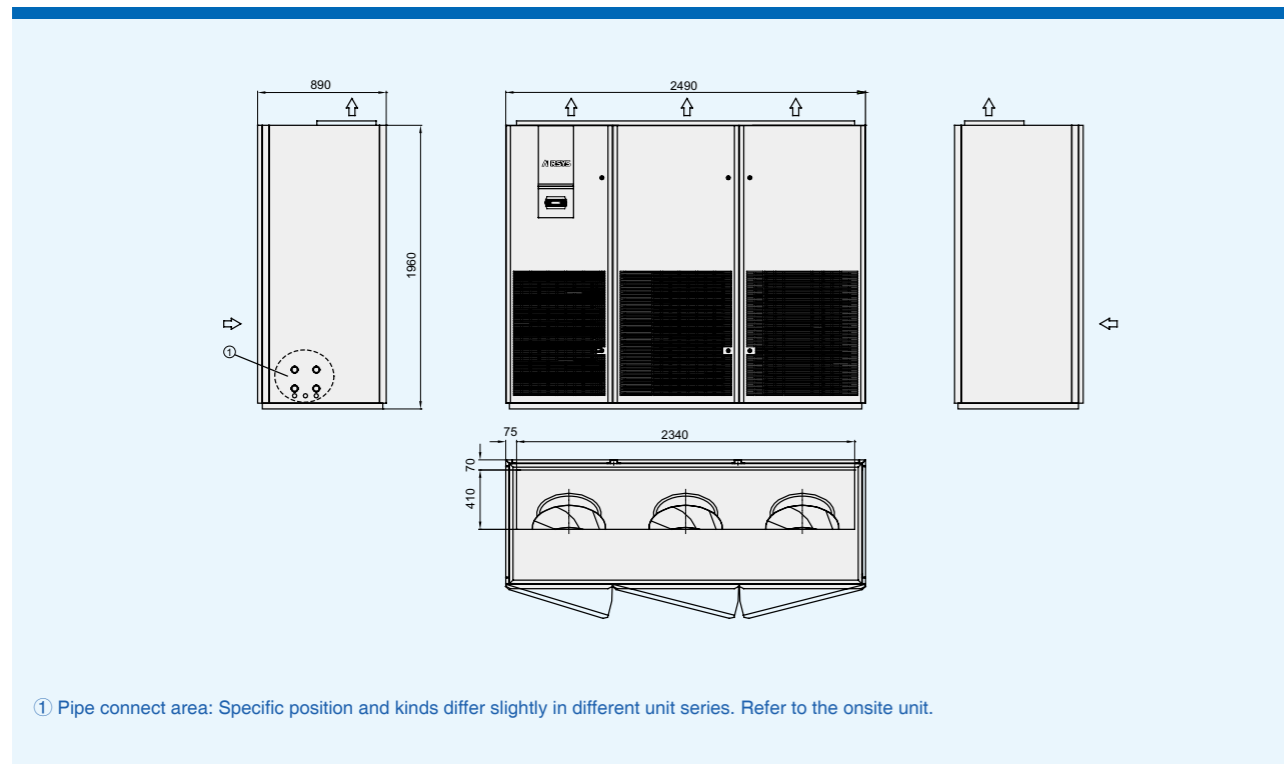

A5 Unit Cabinet Dimension Drawing for Up Flow Unit

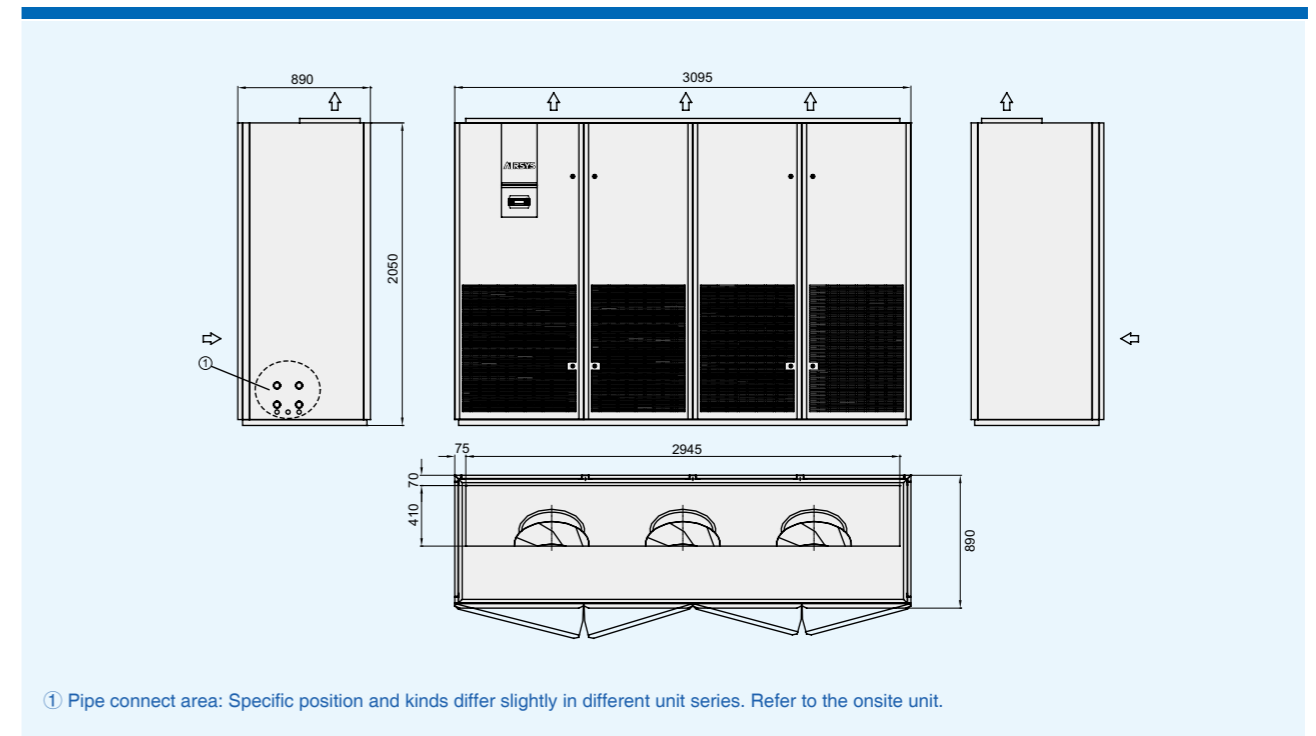

A4 Unit Cabinet Dimension Drawing for Under Flow Unit

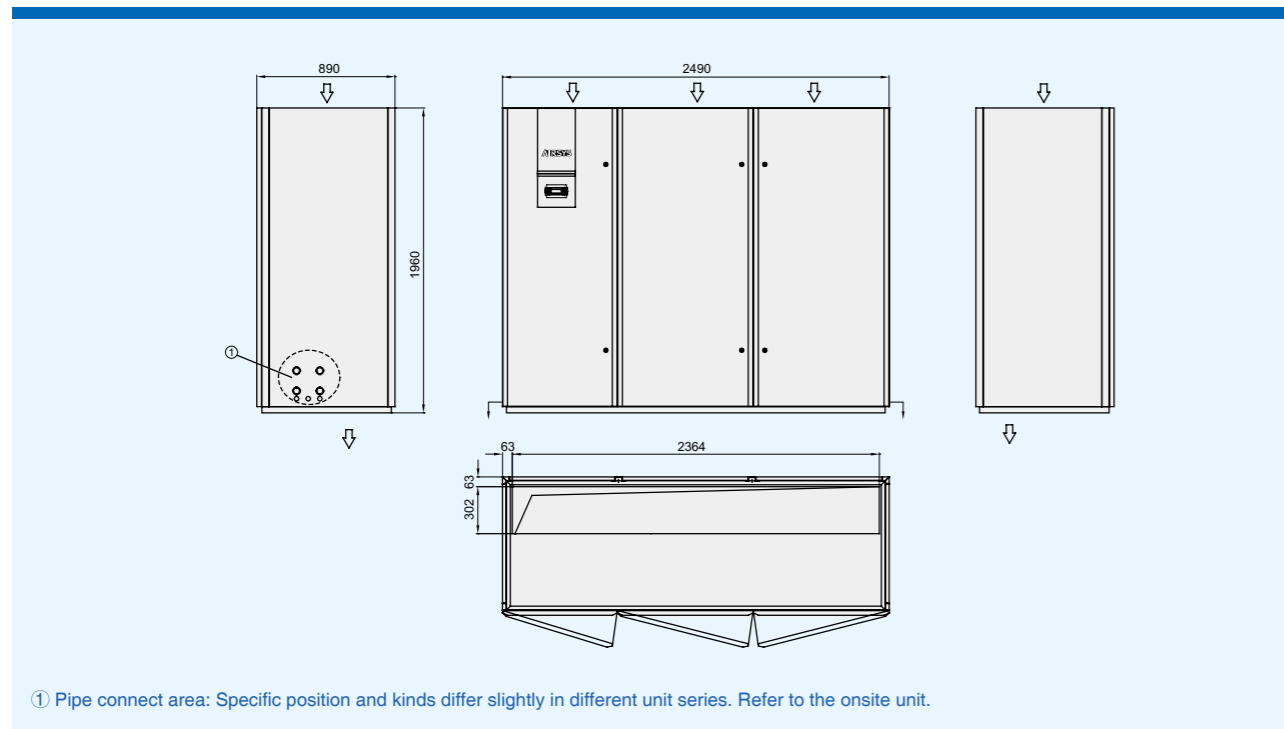

A5 Unit Cabinet Dimension Drawing for Under Flow Unit

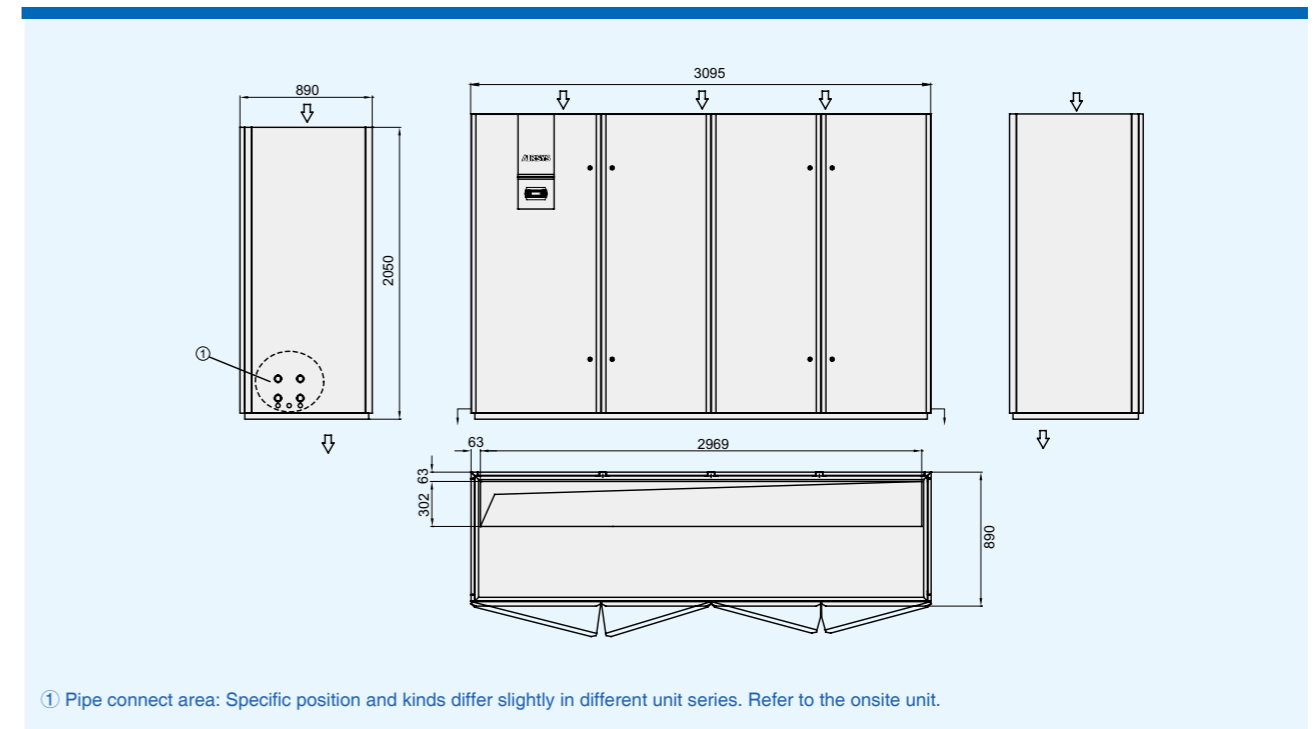

OPTIMA-DFC Fresh Air Inlet Box Dimension Drawing

S1 Fresh Air Inlet Box

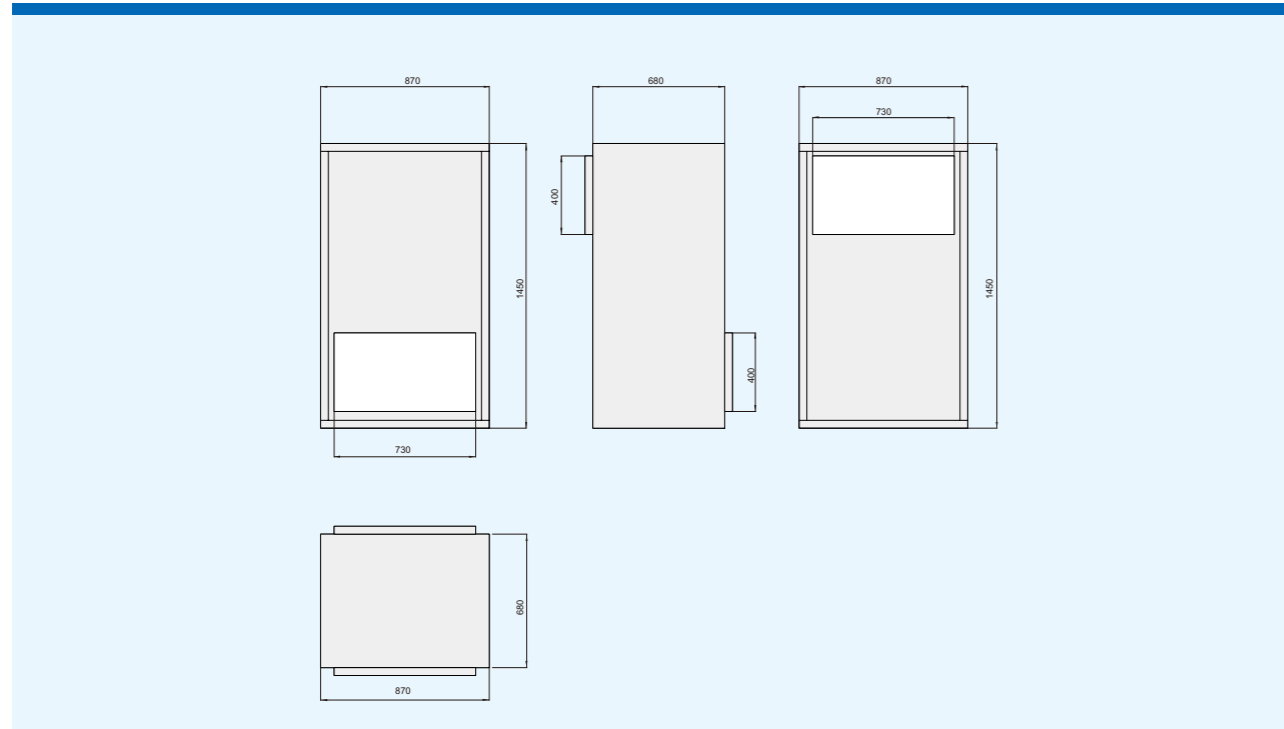

S2 Fresh Air Inlet Box

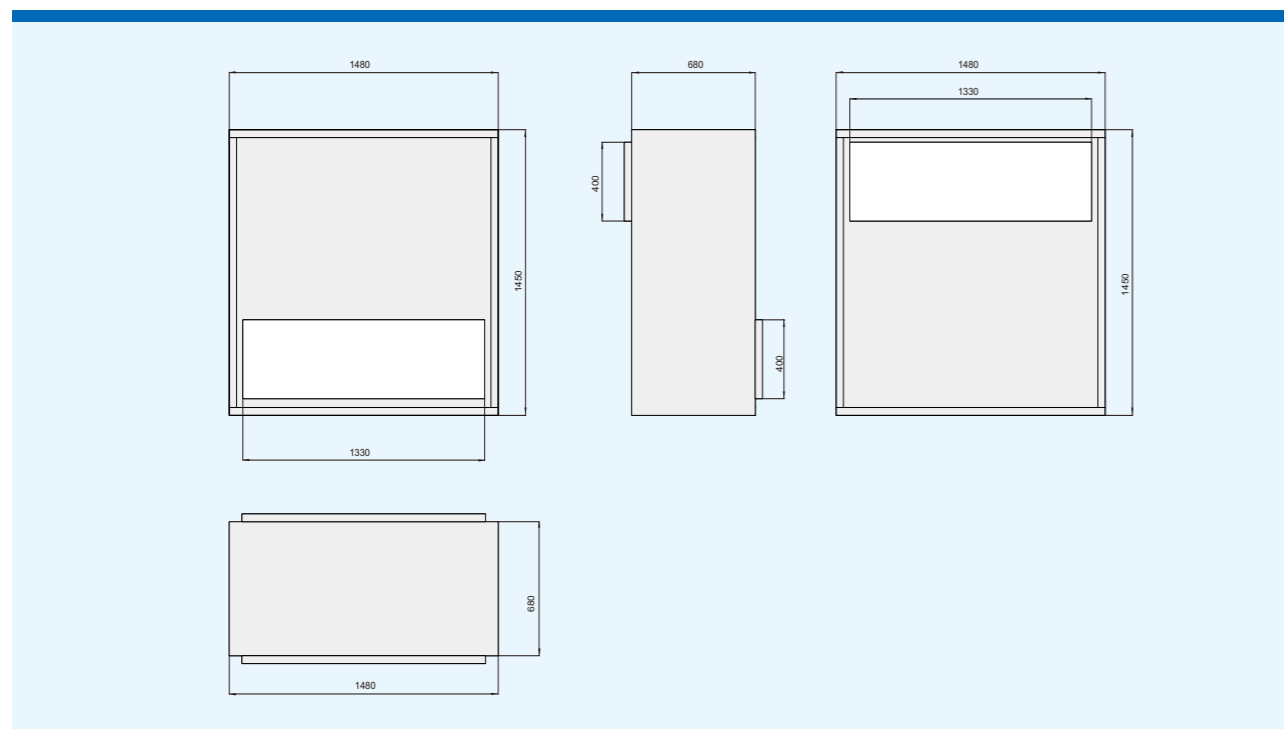

Air Cooled Condenser Dimension Drawing

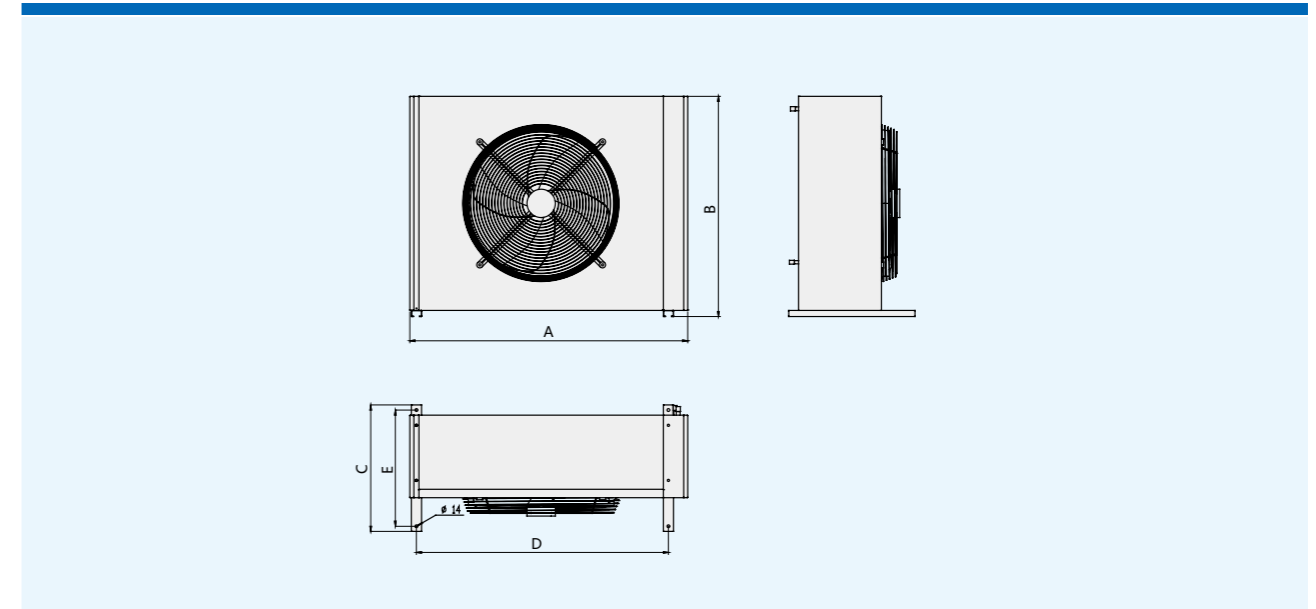

	CME(G)4	CME(G)5	CME(G)8	CME(G)10	AMAE5	AMAE6	AMAE8	AMAE10
A	840	1140	1340	1340	1365	1365	1665	1665
B	770	770	1070	1070	1080	1080	1080	1080
C	475	475	620	620	620	620	620	620
D	737	1037	1237	1237	1237	1237	1537	1537
E	425	425	570	570	570	570	570	570

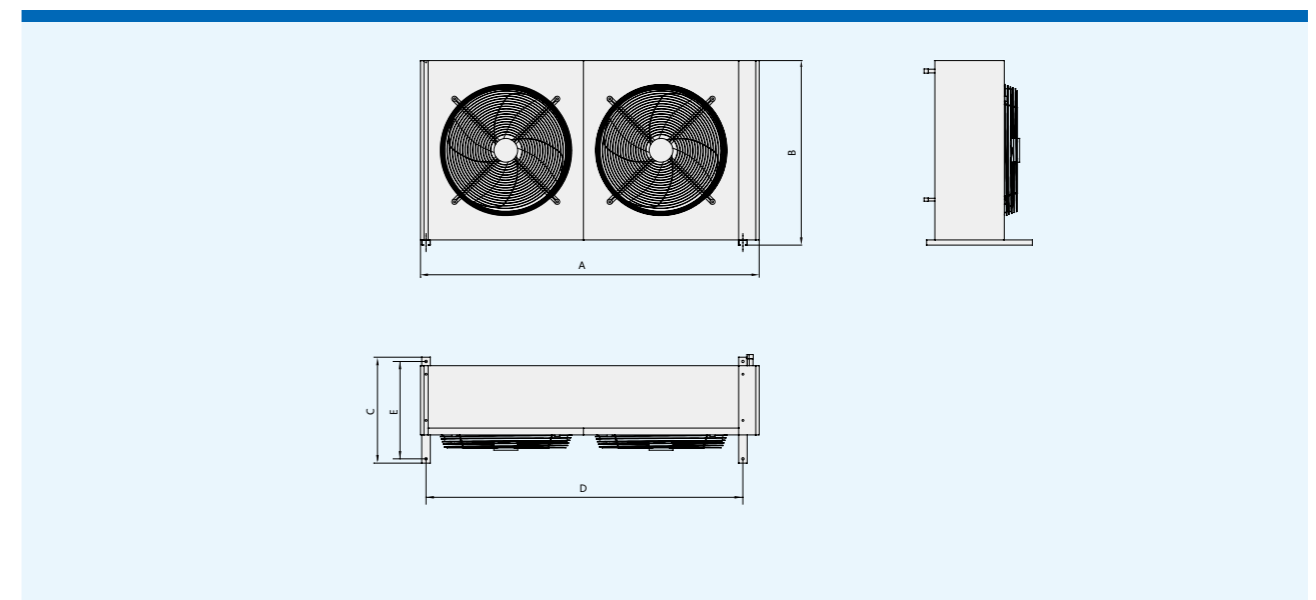

	CME(G)15	CME(G)20	CME(G)25	AMAE12	AMAE15	AMAE18	AMAE20
A	1540	2400	2400	1985	1985	2785	2785
B	1070	1135	1135	1080	1080	1080	1080
C	620	630	630	620	620	620	620
D	1437	2160	2160	1857	1857	2657	2657
E	570	580	580	570	570	570	570

Remark: Vertical installation type is default, please indicate in the contract if horizontal installation type is required.

CMEH Dry Cooler Dimension Drawing

CMEH20/CMEH30

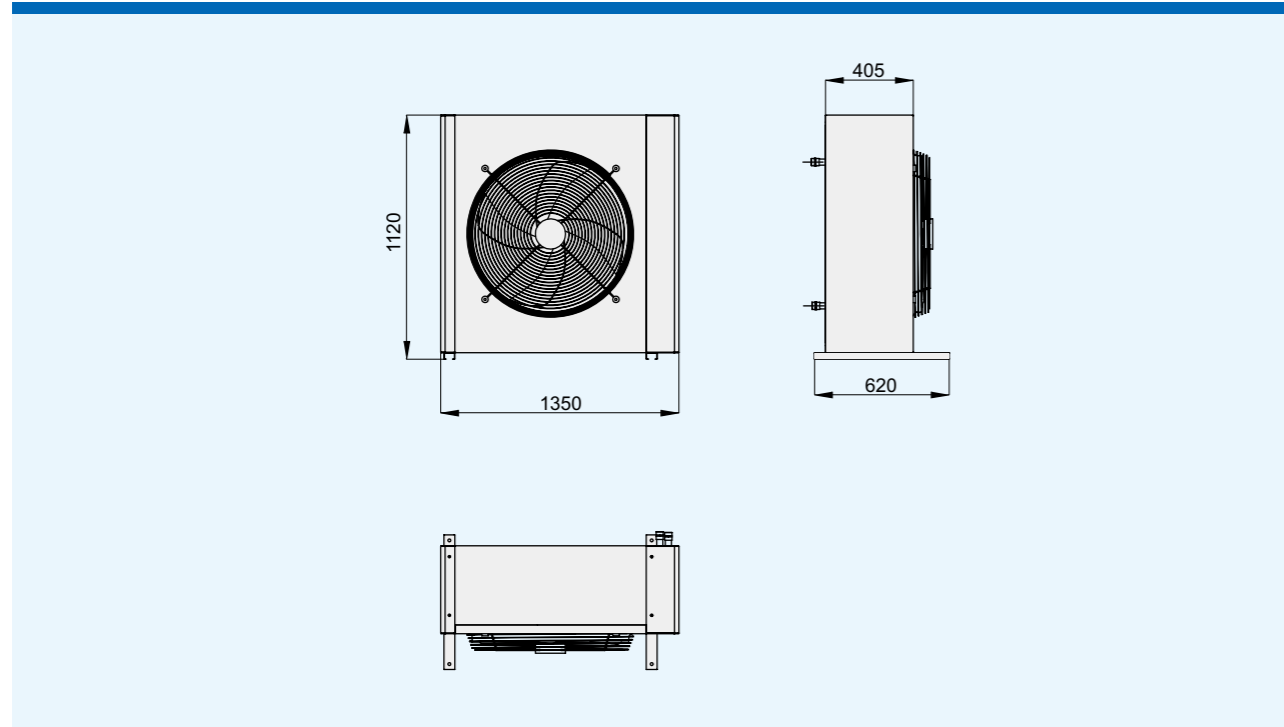

CMEH70/CMEH80

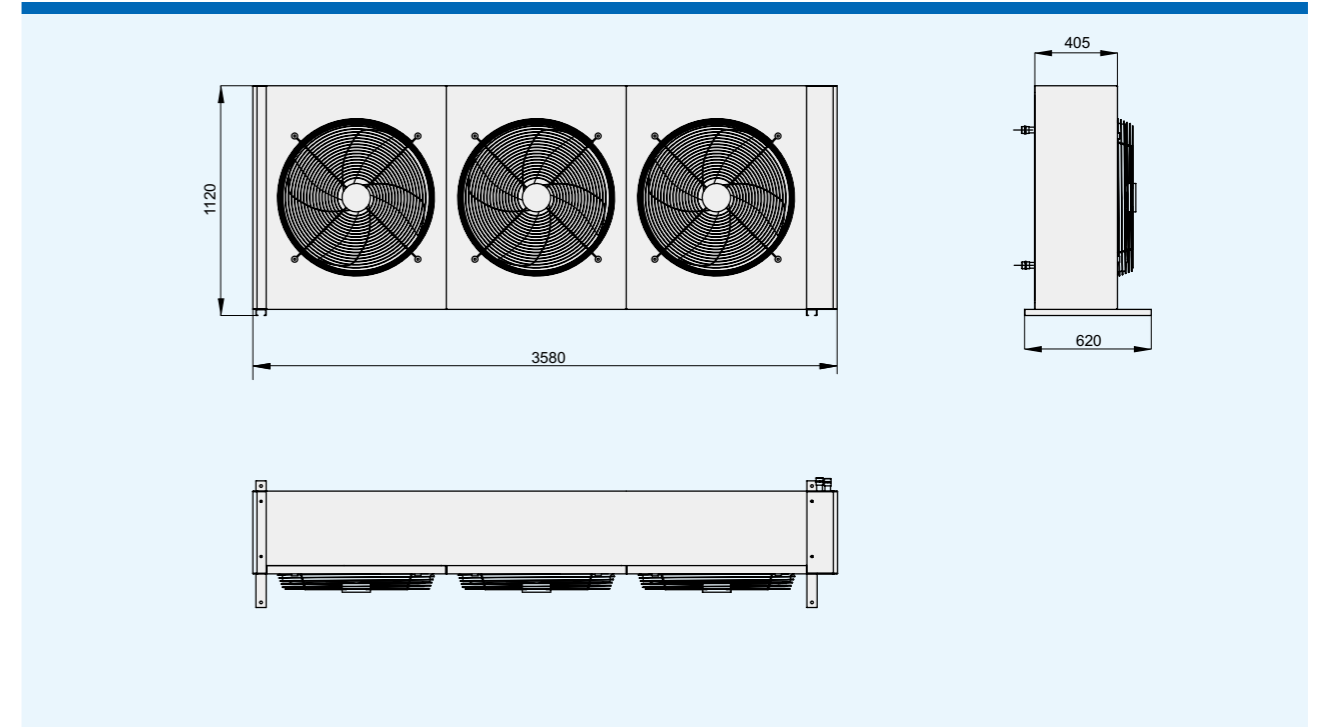

CMEH40/CMEH50/CMEH60

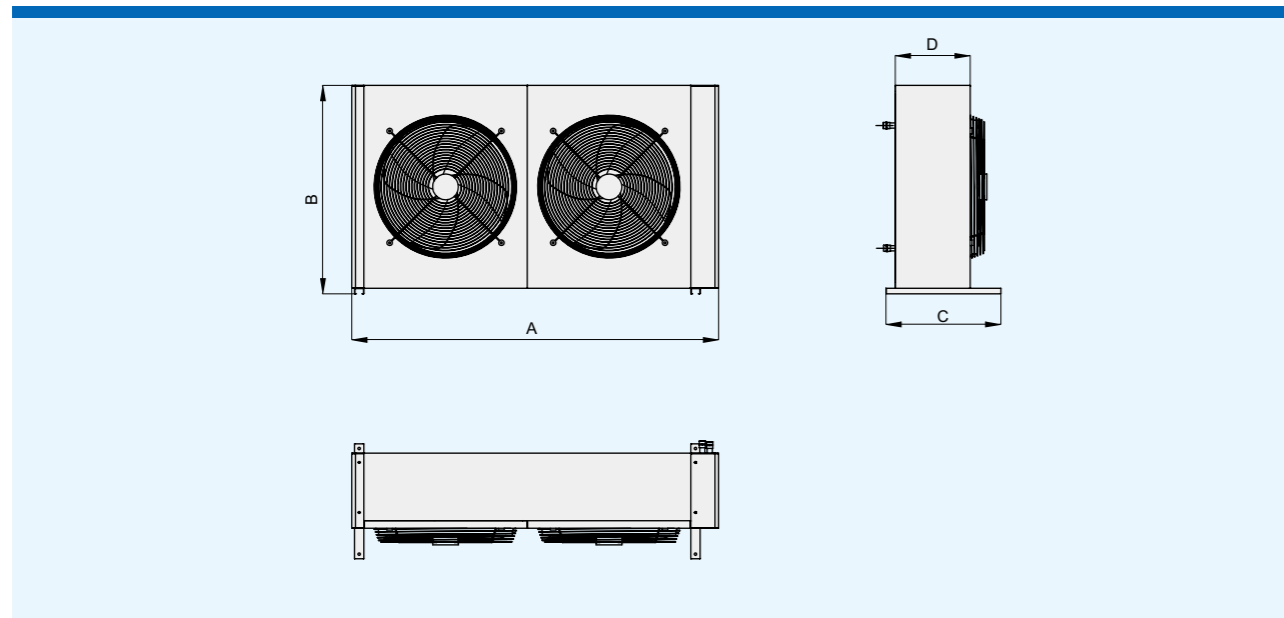

	CMEH40	CMEH50	CMEH60
A	1980	2700	2700
B	1120	1120	1120
C	620	620	620
D	405	405	405

PUG Pump Group Dimension Drawing

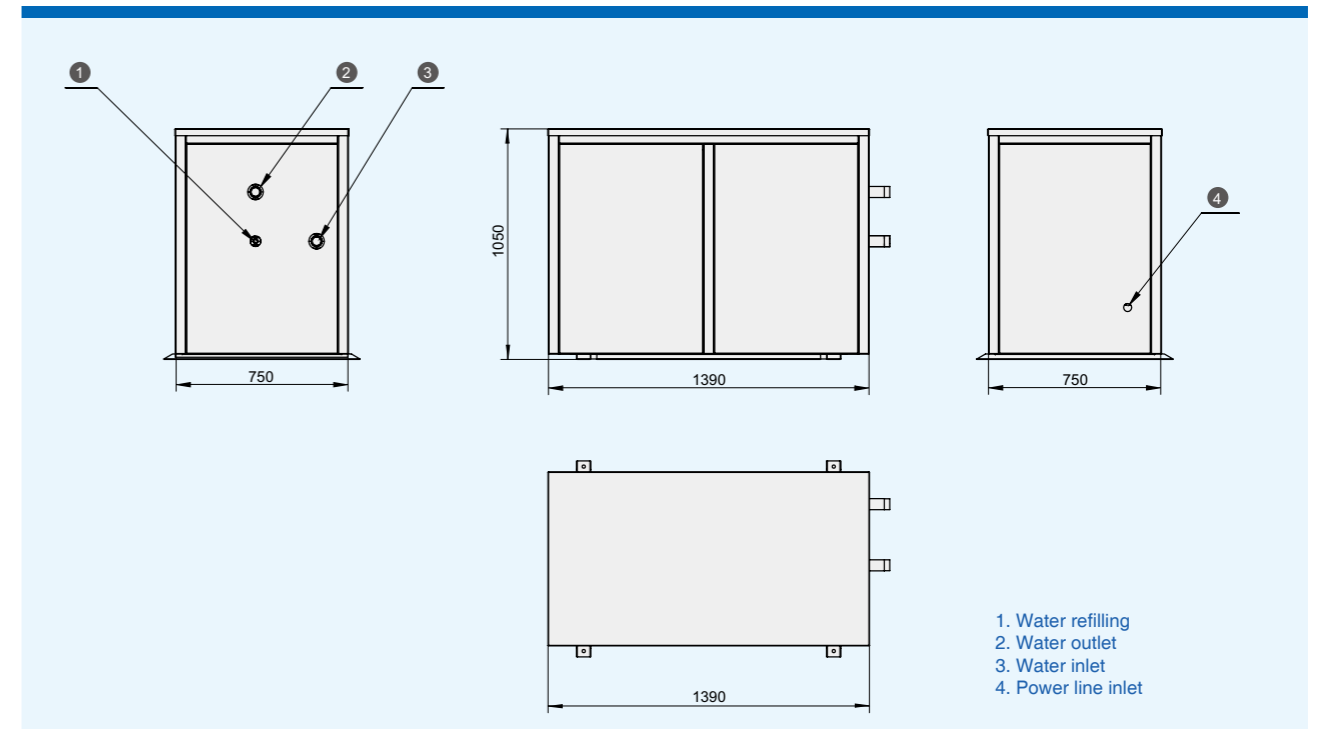

- 1. Water refilling
- 2. Water outlet
- 3. Water inlet
- 4. Power line inlet



Airsys Refrigeration Engineering Technology (Beijing) Co., Ltd.

Add: 10th floor, Hongkun Shengtong building, 19, Ping Guo Yuan Xi Xiao Jie, Shijingshan, Beijing, China 100043
Tel: +86(0)10 68656161

Gu'an Airsys Environment Technology Company Ltd.

Add: 25, Dongfang Street, Gu'an Industry Park, Langfang City, Hebei Province, China
Tel: +86(0)10 68656161

Shanghai Airserve HVAC System Service Co., Ltd.

Add: #7-2, No.658, Daduhe Rd., Putuo District, Shanghai, China, 200333
Tel: +86(0)21 62452626 Fax: +86 (0)21 62459622

AIRSYS Australia Sales Office

Add: PO BOX 1088, Flagstaff Hill, SA, 5159, Australia
Tel: +61 479151080

AIRSYS BRASIL LTDA.

Add: Av. Moaci, 395 Conj 35/36 04083-000 – Planalto Paulista SAO PAULO – SP
Tel: +55 (11) 25976817 / +55 (11) 21585560

AIRSYS Deutschland GmbH

Add: Dahlweg 120, D-48153 Münster Germany
Tel: +49 (0) 1757535054 / 251-97307478

AIRSYS Klima Sanayi ve Ticaret A.Ş.

Add: Barbaros Mah. Evren Cad. Erzurumlular Sk. No:23 Ataşehir / Istanbul Turkey
Tel: +90(216) 4706280 Fax: +90(216) 4706290

AIRSYS North America, LLC

ICT Cooling:

Add: 915 De La Vina St. Santa Barbara, CA 93101, USA
Tel: +1 (805) 312 7563 Call Centre: +1 (855) 874 5380

Medical Cooling:

Add: 3127 Independence Dr Livermore, CA 94551, USA
Tel: +1 800 7131543

AIRSYS Singapore Pte. Ltd

Add: 12 Lorong Bakar Batu #06-01 Singapore (348745)
Tel: +65 62787188 Fax: +65 68416301

AIRSYS (UK) Ltd.

Add: 245 Europa Boulevard, Warrington, UK. WA5 7TN
Tel: +44 (0) 1925 377 272 Call Centre: +44(0)8456099950

www.air-sys.com

Product design and specification subject to change without prior notice.